



**YAMoRC**®  
DIGITAL

# YD8116 SWITCH

## 16-FOLD SIGNAL/SWITCHING DECODER

### FREE CONFIGURABLE QUICK START

(2025-04-09)



Designed by Karst Drenth  
Made in Germany  
Assembled in NL

**Index**

[Description.....](#) 3

[Technical Data.....](#) 4

[Assembly, dimensional drawing.....](#) 4

[Important notes.....](#) 5

[Hardware overview.....](#) 6

[Connection of power supply.....](#) 7

[Connection Examples.....](#) 8

[Configuring the start solenoid address  
\(switch address\).....](#) 10

[Configuration via "ES-Link".....](#) 11

[What is DCCext and why is it advantageous to use the  
use it? A short insight!.....](#) 12

[Warranty.....](#) 13

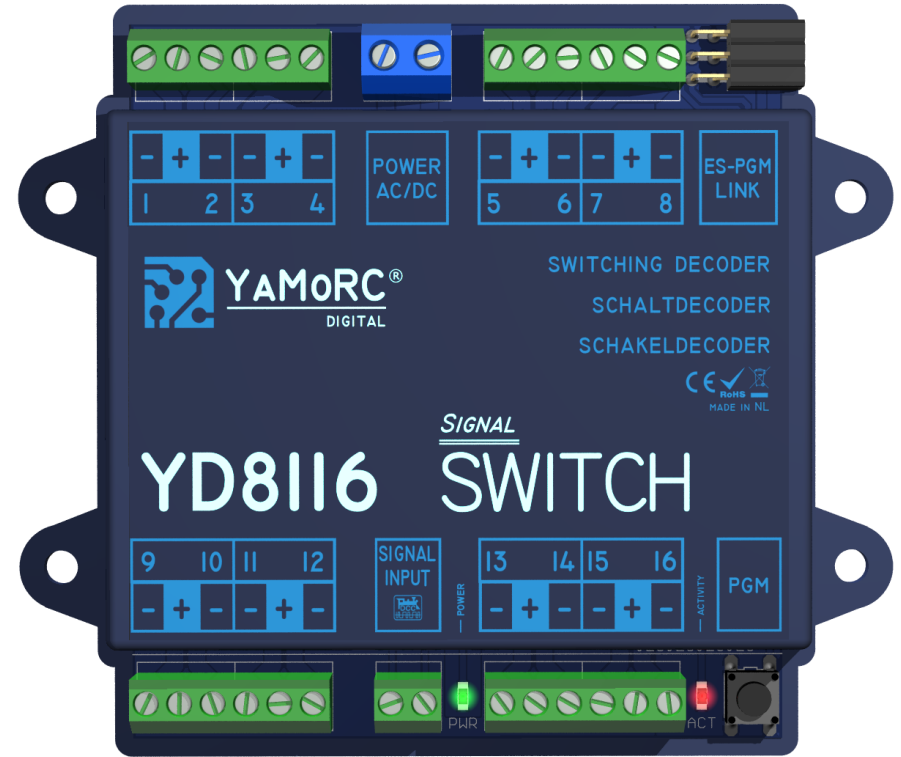

## Description

- The **YD8116** has sixteen outputs. The outputs can be freely configured for various switching tasks, e.g. light signals, lighting or for MTB® actuators (MP-1 and MP-5).
- If motorised point machines are used that are controlled by reversing the polarity of the motor (e.g. Conrad®, Hoffmann®), the **YD6940** adapter must be used.
- When using Motorised point machines, it may be useful to activate the output time limit for some drives. Please refer to the instructions for the drives used.
- The **YD8116** is not intended for the operation of normal solenoid coil drives (turnout drives e.g. from Roco®, Fleischmann®, Piko®, Märklin®, etc.). For switching solenoid coil drives, please use our accessory decoders for solenoid coils **YD8008** or **YD8044**.
- The **YD8116** can be controlled either via "normal" DCC turnout addresses or via the relatively new DCCext format. For multiple term signals DCCext offers the advantage that no complicated DCC address combinations have to be switched. Furthermore, the use of DCCext saves normal turnout addresses. For example, an exit signal with four switching terms requires only a single turnout address, whereas conventionally two DCC addresses are needed. A DCCext command consists of the DCC switching address and a value between 0 and 255. For more detailed information please refer to the RCN-213 standard. Note that the command station you are using must support the DCCext format.
- The solenoid address (turnout address) is configured simply by pressing the **programming button**. We have deliberately decided to keep the configuration as simple as possible, for this reason no further settings are required on the YD8116 for normal operation. Only a freely selectable solenoid address (turnout address) must be assigned as the start address. The YD8116 then automatically occupies the seven consecutive solenoid article addresses.
- In the basic configuration (delivery state), the **YD8116** is configured for 8 light signals with two LEDs and fading of the signal aspects configured. Attention! Because of the preconfigured fading function, no normal solenoid drives (Piko, Roco etc.) may be operated.
- The **YD8116** is conveniently configured via the "ES-PGM Link" connector. Please note that either a programming module (YD 9100, YD9101) or a YaMoRC module with an "ES-IN Link" connector (e.g. YD6016LN-xx) is required for this. By configuring via the "ES-Link" it is possible, among other things, to freely assign the switching addresses, to select ready-made signal definitions or to configure switching aspects for DCCext. If needed, please download the extended guidance.
- **Attention!** If a **firmware update** is carried out via "ES-Link", the current configuration of the **YD8116** should be saved in a freely selectable directory using the "Export data" function.

**Technical Data:**

|                                  |   |
|----------------------------------|---|
| Number of Outputs                | 16 outputs (short-circuit proof up to 3A) |
| Digital Format                   | DCC and DCCext                            |
| Address Area                     | 1-2048                                    |
| Load capacity of a single output | 2.5 A                                     |
| Total current of all outputs     | 5A  |
| Input Voltage AC                 | Min. 10 VAC<br>Max. 16 VAC                |
| Input Voltage DC                 | Min. 12 VDC<br>Max. 19 VDC                |
| Housing Dimensions               | 84mm x 88mm x 22mm                        |
| Distance Between Holes           | 94.5mm, 42.5mm                            |

**Mounting**

The YD8116 is mounted via the four mounting holes on the side of the housing.

**Dimensional Drawing**

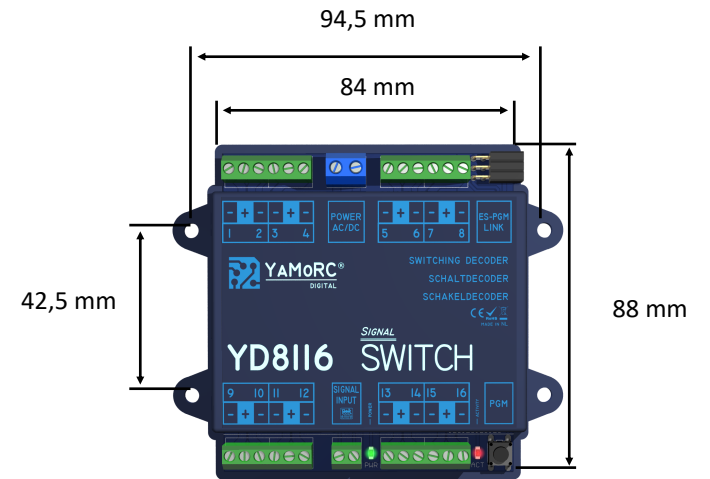

### Important Notes (Including Health & Safety):

- The YD8116 is intended exclusively for operation on an electric model railway.
- The YD8116 is not a toy and is therefore not suitable for children under 14 years of age.
- Never operate the YD8116 unattended.
- Voltage sources (power supplies, transformers, etc.) must comply with the current VDE/EN and CE standards.
- The voltage sources used (power supplies, transformers) must comply with protection class 2. Failure to comply may result in serious damage to the YD8116. The voltage sources must be marked with this symbol.



Further information on the protection class can be found here, for example: <https://www.google.com/search?q=schutzklasse+2&oq=schutzklasse+2>

- Direct voltage sources (**DC**) must not exceed a maximum power of **60W**.
- AC voltage sources (**AC**) must not exceed a maximum output current of **3A**.
- Voltage sources must be fused in such a way that a cable fire cannot occur in the event of a fault.
- AC transformers must not exceed a maximum output voltage of 16V AC. The YD8116 internally rectifies AC voltage and always outputs DC voltage at the output terminals. The polarity of the output terminals (- + -) must be observed!
- A common earth connection of different voltage sources or circuits is not permitted. This will destroy the YD8116.
- It is essential to ensure a sufficient wiring cross-section of the individual connections.
- The connection terminals for power are designed for a cross-section of 0.75 mm<sup>2</sup>. All other connection terminals are designed for a cross-section of 0.5 mm<sup>2</sup>.
- Connection work must always be carried out in a de-energised state. Disconnect or switch off power AC/DC and signal input.
- Discharging the internal power storage unit (CDU) takes approx. 10 minutes; all connection work may only be carried out after this time.
- The YD8116 must never be installed near sources of intense heat such as radiators or places exposed to direct sunlight. Therefore, install the YD8116 in a place with sufficient ventilation to be able to dissipate the waste heat.
- The YD8116 is designed for dry indoor use only. Therefore, do not operate the YD8116 in environments with large fluctuations in temperature and humidity or outdoors.
- Do not attempt to open the YD8116. Improperly performed actions can lead to the destruction of the YD8116.

## Hardware Overview

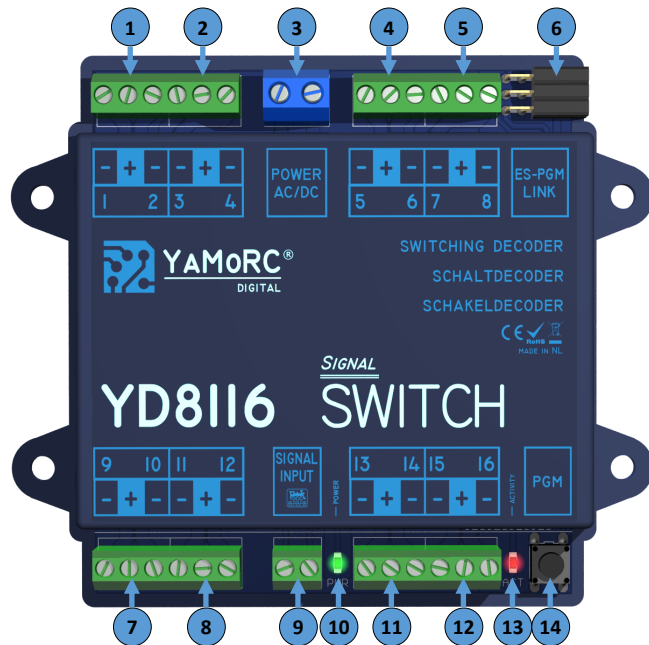

|   |   |
|---|---|
| 1 | 1 connection output 1<br>+ <b>common connection</b> output 1/2<br>2 Connection output 2   |
| 2 | 3 connection output 3<br>+ <b>common connection</b> output 3/4<br>4 Connection output 4   |
| 3 | <b>Power AC/DC</b> <b>Connection of the power supply for the solenoids</b><br>Input voltage AC (alternating voltage)<br>min. 10 VAC max. 16 VAC / 3A<br>Input voltage DC (direct voltage)<br>min. 12 VDC max. 19 VDC / 60 W |
| 4 | 5 connection output 5<br>+ <b>common connection</b> output 5/6<br>6 Connection output 6   |
| 5 | 7 connection output 7<br>+ <b>common connection</b> output 7/8<br>8 Connection output 8   |

|    |  |
|----|--|
| 6  | <b>ES-PGM Link</b> <b>YaMoRC programming adapter connection</b><br>The YaMoRC programming adapter can be used to perform firmware updates and advanced programming can be performed. |
| 7  | 9 connection output 9<br>+ <b>common connection</b> output 9/10<br>10 Connection output 10   |
| 8  | 11 connection output 11<br>+ <b>common connection</b> output 11/12<br>12 Connection output 12  |
| 9  | <b>Connection DCC track signal (track voltage)</b>   |
| 10 | <b>Green LED</b> display Supply voltage on Power present or landing process of the power storage unit in progress. Landing process of the power storage unit is in progress.         |
| 11 | 13 connection output 13<br>+ <b>common connection</b> output 13/14<br>14 Connection output 14  |
| 12 | 15 connection output 15<br>+ <b>common connection</b> output 15/16<br>16 Connection output 16  |
| 13 | <b>Red LED</b> Display Activity<br>One pulse of the LED one solenoid address is controlled   |
| 14 | <b>Programming button</b>  |

## Connecting the power supply

The YD8116 can be powered either directly from the control panel or with a separate DC power supply (recommended) or AC transformer.

Power supply of the YD8116 directly via the digital central unit

**Attention:** If a 6016LN-xx is used to configure the YD8116 is used, the connection from Power AC/DC to the track out of the central unit or a booster must be disconnected

Power supply of the YD8116 via a separate power pack (DC) or a transformer (AC) with min. 500 mA output current

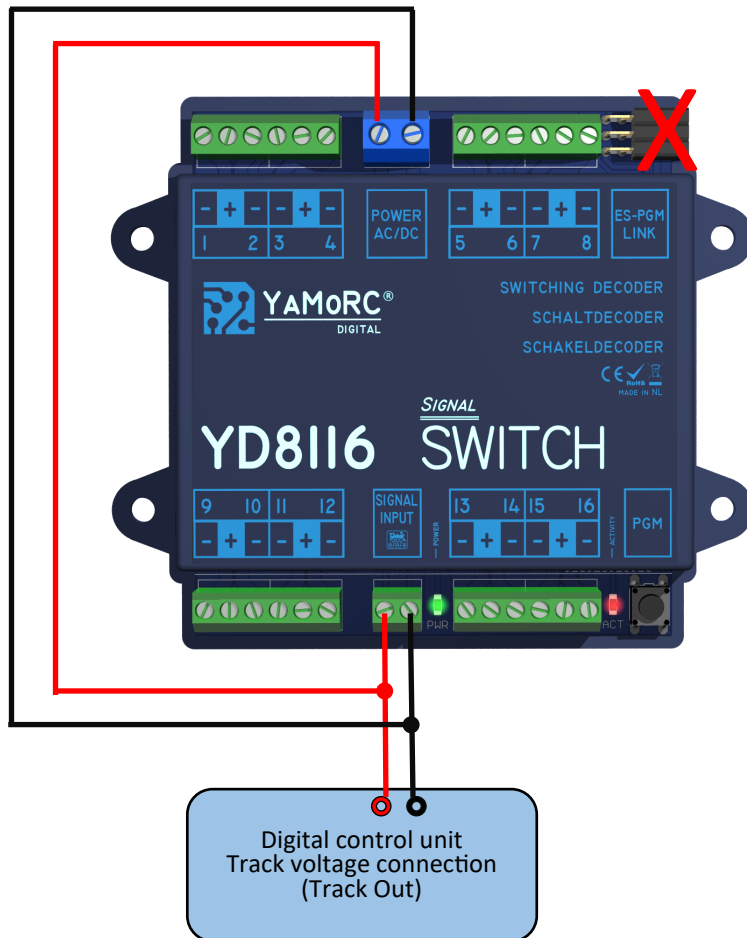

Voltage source  
Power supply unit  
(DC) 12-19 VDC  
Transformer  
(AC) 10- 16 VAC

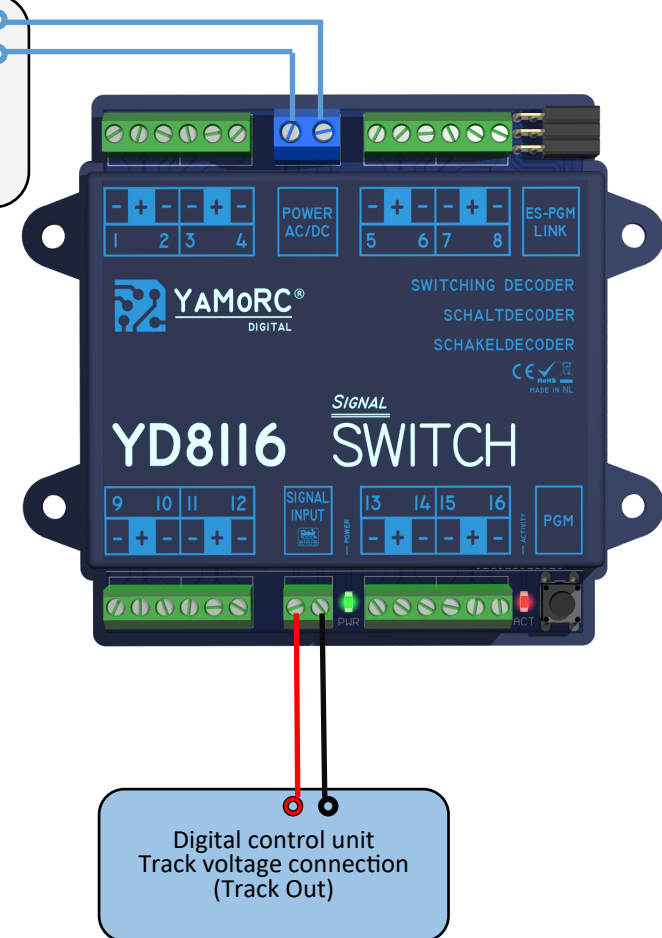

### Attention!

All connection work on the YD8116 must always be carried out in a de-energised state. Disconnect the power supply from the mains and switched off!

### Connection examples

Connection of a block signal with two outputs and a retract signal with three outputs as well as configuration on the YD8116

Connection of an exit signal with five outputs and configuration on the YD8116

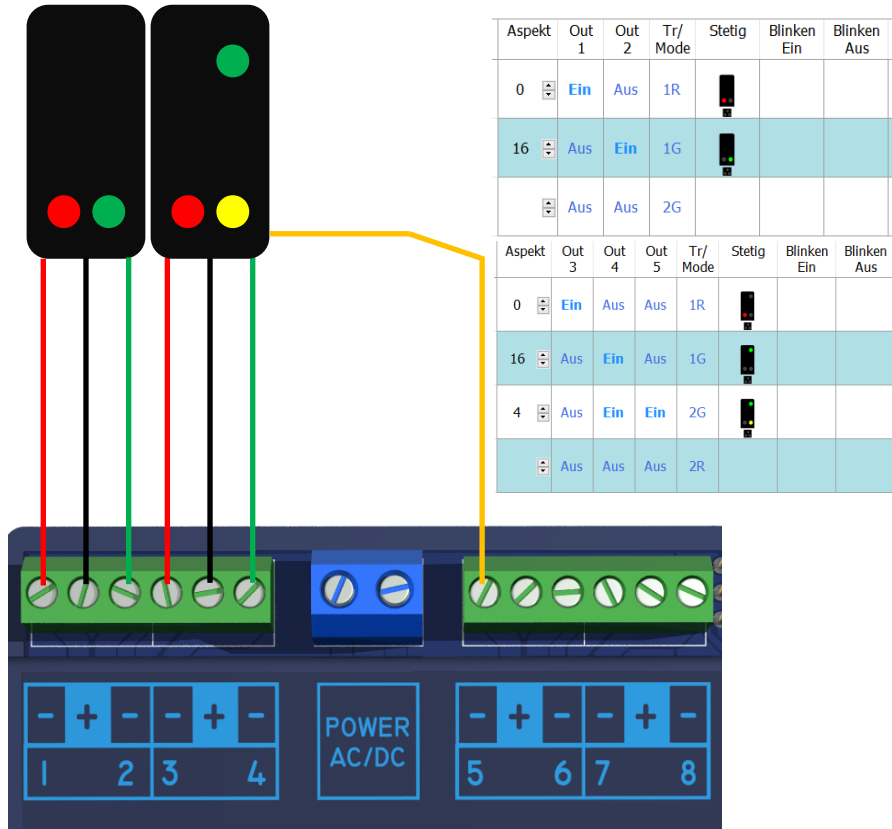

**!** Please note that LEDs may only be connected to the YD8116 with a series resistor for current limitation. It is irrelevant whether the LED is dimmed or operated at full brightness. The resistor value depends on the type of LED used, so it is not possible to say exactly how high this value must be. Commercially available LEDs can be operated with a series resistor of approx. 2.2 - 10 kΩ. If in doubt, start with a higher resistor value.

**Attention!**  
All connection work on the YD8116 must always be carried out in a de-energised state. Disconnect the power supply from the mains and switched off!

### Connection examples

Connection examples MP-1 and MP-5 point machines from MTB<sup>®</sup> and configuration on the YD8116

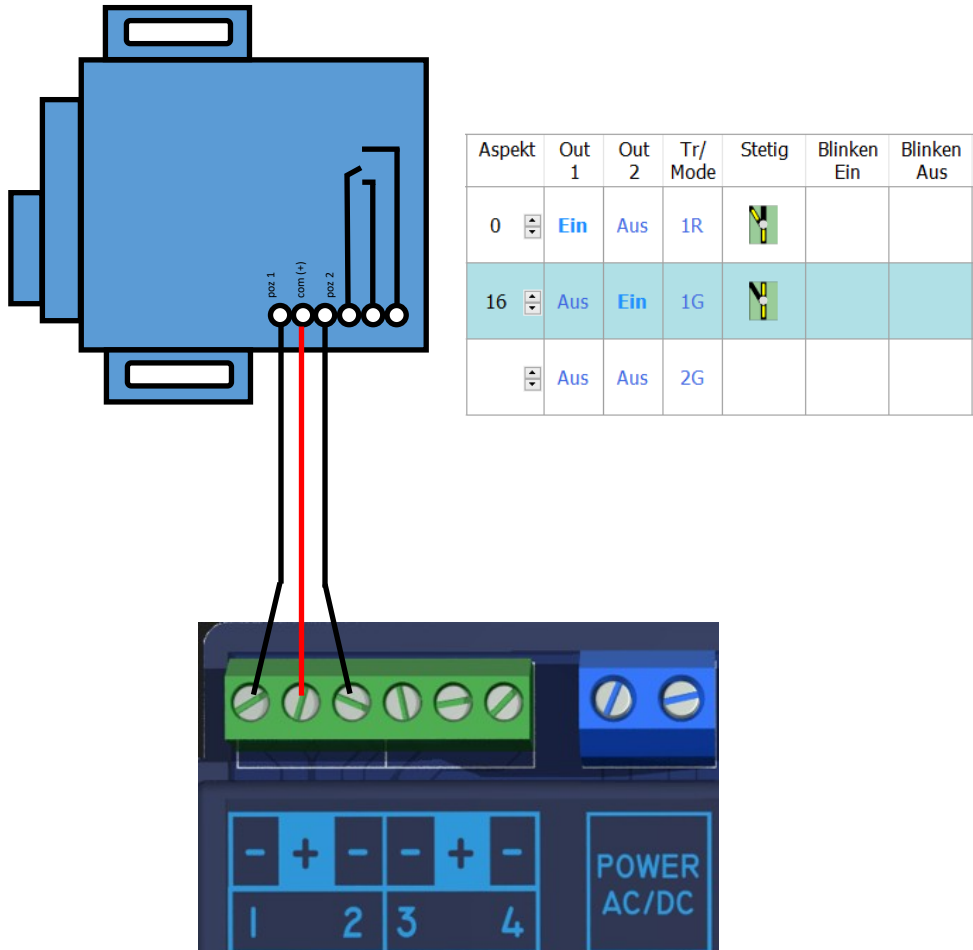

Connection examples of the shape signal and the configuration in the YD6116 .The line colours may differ! Please observe the operating instructions of the signals used

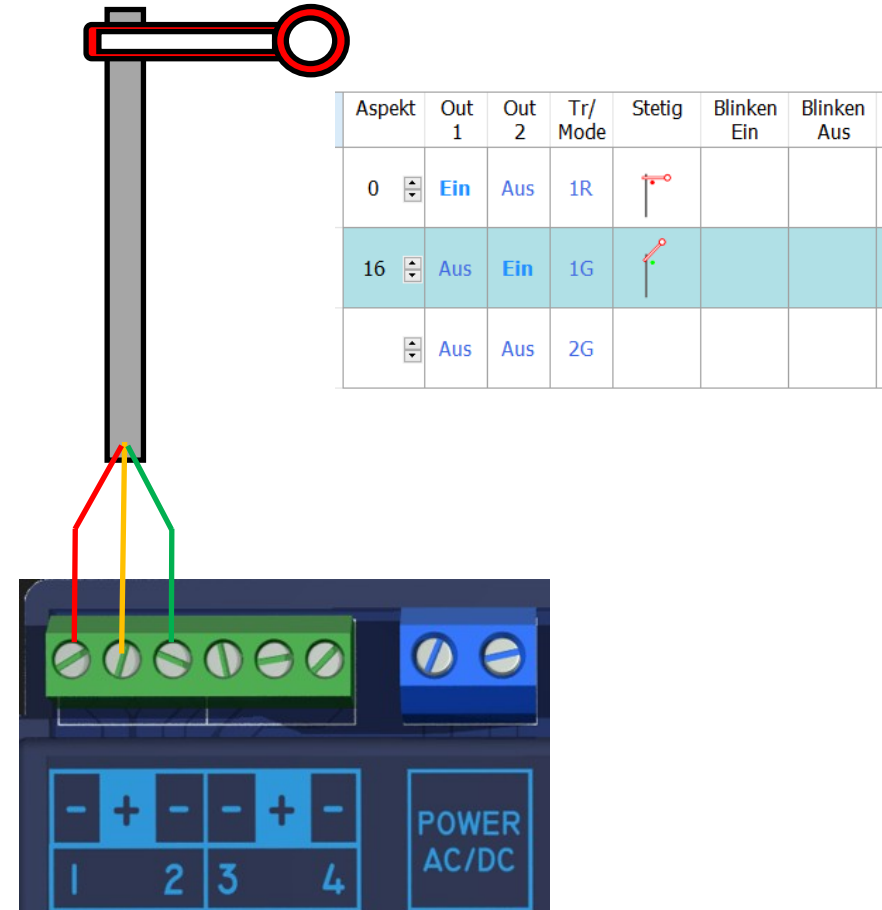

**Attention!**

All connection work on the YD8116 must always be carried out in a de-energised state. Disconnect the power supply from the mains and switched off!

## Configuring the start solenoid address (turnout address)

YaMoRC has decided to make the configuration of the YD8116 as simple as possible. For this reason, the YD8116 does not have the CV programming that was common in the past.

If you have any questions, please contact our service department. We will certainly find a solution for you.

### Configuration of the start solenoid address

1. Connect the power supply to the power input. 1
2. Connect the signal input to the track voltage output of the central unit. 2
3. Switch on the power supply via Power and the control unit.
4. Call up the turnout control panel of the central unit and the turnout address to be assigned as the start address. Do not carry out a switching operation yet! *(For the exact procedure on how to call up a turnout control panel, please refer to the documentation of your central unit or app).*
5. Press the programming button to put the YD8116 into configuration mode. The red LED next to the button will light up continuously to indicate that the YD8116 is in configuration mode. 3
6. Press the desired turnout address to be used as the start address once on the turnout control panel of the central unit. The following seven solenoid addresses are assigned automatically. Thus, the YD8116 occupies eight consecutive solenoid addresses. *(For the exact procedure for switching a turnout address, please refer to the documentation of your control unit or app).*
7. The assignment of the solenoid addresses is completed and the YD8116 automatically exits configuration mode. (The red LED next to the programming button goes out).

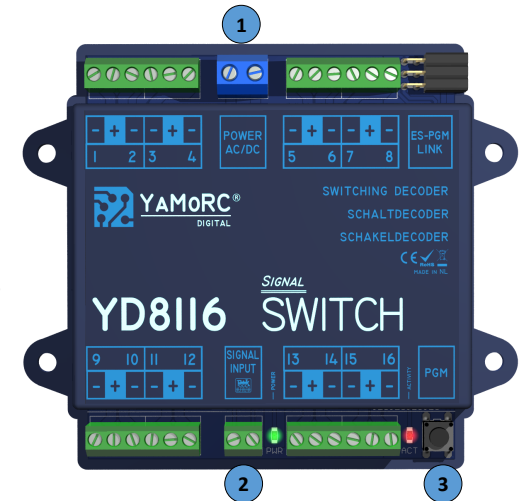

### Attention!

All connection work on the YD8116 must always be carried out in a de-energised state. Disconnect the power supply from the mains and switched off!

## Configuration via "ES-Link"

Here we present the simplest configuration option of the YD8116 via predefined signals and switching terms. A YaMoRC module with "ES-IN Link" connection is always required for configuration (e.g. YD6016LN-xx, YD9101). For a detailed description of how to connect the YD8116 to the YD6016LN-xx or the YD9101, please refer to the respective documentation.

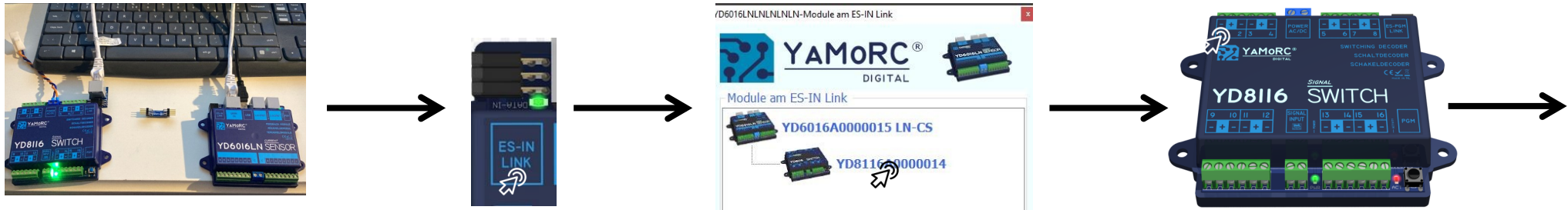

YD8116 via the YD6902ES-EXT and a normal network cable or a YD6901ES-LINK to the configuration module (e.g. YD6016LN-xx).

Click the ES-IN Link symbol on the configuration module.

Select the YD8116 from the selection list by double-clicking on it.

The configuration interface of the YD8116 is started.

Clicking on the desired output opens the configuration menu for the selected output.

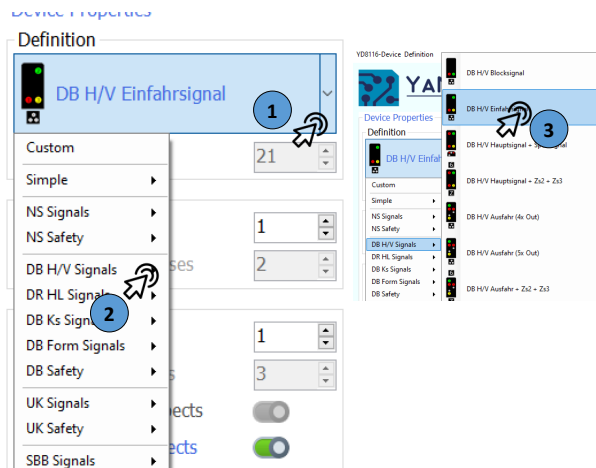

Select the desired signal definition by mouse click.  
Example: DB entry signal

Aspects

|  | Aspect | Out 1 | Out 2 | Out 3 | Tr/ Mode | Steady | Blink On | Blink Off |
|--|--------|-------|-------|-------|----------|--------|----------|-----------|
|  | 0      | On    | Off   | Off   | 1R       |        |          |           |
|  | 16     | Off   | On    | Off   | 1G       |        |          |           |
|  | 4      | Off   | On    | On    | 2G       |        |          |           |
|  |        | Off   | Off   | Off   | 2R       |        |          |           |

The outputs and signal aspects are assigned automatically based on the selected signal definition. To save outputs, the YD8116 assigns the outputs consecutively without gaps. The DB entry signal shown here occupies outputs 1-3. The next signal can be configured continuously from output 4.

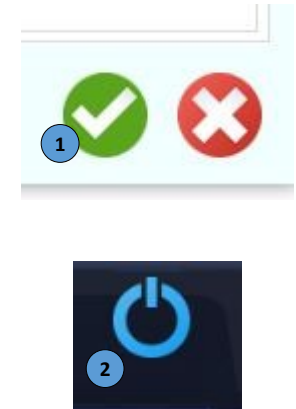

Save the configuration (1) and then exit the configuration tool (2).

## What is DCCext and why is it beneficial to use it? A short look!

The YD8116 can be controlled either via "normal" DCC turnout addresses or via the relatively new **DCCext format**.

### Shortly summarized the distinction:





With multiple term signals, switching via "normal" DCC addresses can become complicated. Different DCC switching commands must be executed in a certain time and sequence. Which of course also consumes several DCC addresses. If the DCCext format is used, only one DCC address is needed for multiple signal terms to control the different signal terms. The DCC address is simply assigned a value from 0 to 255. Each value can be assigned to a signal aspect individually.

### What is the advantage of DCCext?

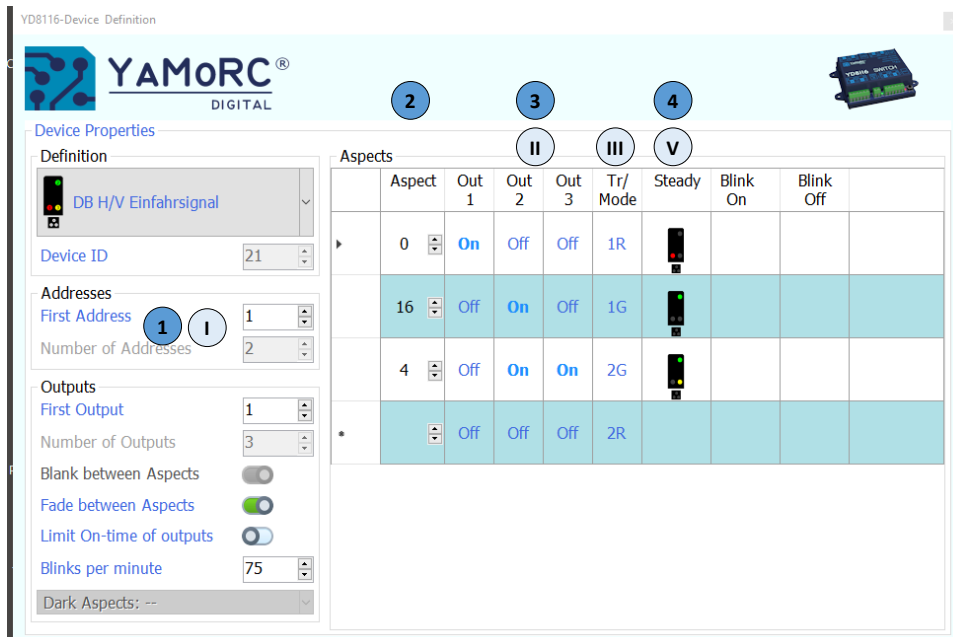
- ⇒ No complicated DCC address combinations have to be switched!
- ⇒ The use of DCCext saves normal turnout addresses!  
So for an exit signal with four switching terms only one turnout address is needed, while conventionally two DCC addresses are needed
- ⇒ Up to 255 switching aspects can be freely assigned.

For more detailed information, please refer to the **RCN-213** standard. It should be noted that the control panel you are using must support the DCCext format.



| Aspect | Out 1 | Out 2 | Out 3 | Tr/Mode | Steady  | Blink On | Blink Off |
|--------|-------|-------|-------|---------|---|----------|-----------|
| 0      | On    | Off   | Off   | 1R      |   |          |           |
| 16     | Off   | On    | Off   | 1G      |  |          |           |
| 4      | Off   | On    | On    | 2G      |  |          |           |
| *      | Off   | Off   | Off   | 2R      |  |          |           |

### Example:

#### DCCext

- 1) Address with which the signal is switched.
- 2) Default aspect number for the respective switching term.
- 3) Initial configuration of the switching terms.
- 4) Pictorial representation of the switching term for the control panel.  
The signal selected signal occupies only one DCC address.

#### DCC

- I. Start addresses with which the signal is switched.  
The signal needs two DCC addresses to be able to display all signal terms.
- II. Initial configuration of the switching terms.
- III. Trigger/Mode.  
Two normal DCC addresses (1R, 1G, 2G) are required for switching the individual signal terms.
- IV. Pictorial representation of the switching term for the control panel.  
The signal selected signal occupies two DCC address.

We have deliberately decided to leave all configuration options open to the user. It is even possible to realise a mixed operation via DCC and DCCext. For this reason, the trigger/mode (how one would control the selected signal via DCC) is always displayed.

## Warranty

### 24 months warranty from date of purchase

Dear Customer,

Congratulations on your purchase from YaMoRC. YaMoRC's high quality products have been manufactured using modern manufacturing processes and have been subjected to careful quality control and tests.

Therefore, when purchasing a YaMoRC product, the company YaMoRC grants you a manufacturer's warranty of 24 months from the date of purchase in addition to the national warranty rights to which you may be legally entitled to, from your YaMoRC specialist dealer as contractual partner.

### Warranty conditions:

This warranty applies to all YaMoRC products purchased from a YaMoRC dealer. Warranty services are only provided if proof of purchase is presented. Proof of purchase is the purchase receipt from the YaMoRC specialist dealer. It is therefore recommended to keep your purchase receipt safe.

### Content of the guarantee/exclusions:

The warranty includes, at YaMoRC's discretion, the free repair or free replacement of the defective part, which can be proven to be due to design, manufacturing, material or transport faults. For this purpose, you must send the decoder to us properly stamped. Further claims are excluded.

### The warranty claims are void:

1. in the case of general wear and tear at expected locations (e.g. screw terminals).
2. in the case of modification of YaMoRC products with parts not approved by the manufacturer.
3. in the case of modification of parts, especially by opening the housing.
4. if the product is used for purposes other than those intended by the manufacturer.
5. if the instructions given by YaMoRC in the operating manual have not been thoroughly read by the user & risked mis-use of the product.

The warranty period is not extended by the repair or replacement delivery. Warranty claims can only be made to your dealer, enclosing any warranty certificate, proof of purchase and a description of the fault. Products sent directly to YaMoRC will neither be treated nor returned free of charge.



### **Drenth Design & Consulting B.V.**

Glazeniershorst 209  
NL-7328 TJ APELDOORN

**Liability:** Drenth Design & Consulting B.V.

**Phone:** +31643392605

**E-Mail:** ddc@yamorc.com

**Directors:** Karst Drenth

**Trade register:** 72184728

**VAT No/Tax ID:** NL-859019901B01