



**YAMoRC**<sup>®</sup>  
DIGITAL



# YD8044 SOLENOID

## 4-FOLD SOLENOID DECODER

### WITH FROG SUPPLY QUICK START

(2025-04-10)



Designed by Karst Drenth  
Made in Germany   
Assembled in NL 

**Contents**

[Description ..... 3](#)  
[Technical data .....4](#)  
[Mounting, dimensional drawing ..... 4](#)  
[Important notes \(including Health & Safety\) ..... 5](#) *Must read before using YD8008*  
[Hardware overview..... 6](#)  
[Connection of the power supply ..... 7](#)  
[Connection examples for solenoid articles ..... 8](#)  
[Connection example two-wire solenoid coil point machines e.g. Kato<sup>®</sup> ..... 9](#)  
[Configuring the start for solenoid address ..... 10](#)  
[Warranty ..... 11](#)



## Description

- The **YD8044** has four three-pole outputs for connecting dual coil drives. In addition, the YD8044 has the ability to easily polarize four turnouts. The relays required for this task are permanently installed in the YD8044 and switch the polarity of the turnout in conjunction with the output of the respective double coil drive.
- The **YD8044** was specially developed for solenoid drives (Peco®, Seep®) that require high power (current) for switching. Thanks to the internal, innovative current storage unit (CDU), there is always enough power available for the solenoid drive (point machine) to switch reliably.
- Of course, the **YD8044** can also be used for "normal" solenoid drives (turnout drives e.g. from Roco®, Fleischmann®, Piko®, Märklin®). The current storage unit (CDU) ensures that these "normal" solenoid drives (turnout drives) switch reliably.
- The **YD8044** is not designed for the operation of turnout drives from **MTB®**. For this purpose, please use the YD8116!
- If you wish to use two-wire solenoid coil drives, e.g. from **Kato®**, on the YD8044, the **YD6940** adapter must be used.
- The current storage unit (CDU) makes it possible to use power supplies (DC) and transformers (AC) with an output current starting at 500 mA, as the charging current of the current storage unit is a maximum of 380 mA. With a standard 2A power source, up to four YD8044s can be operated without overloading the power supply unit or transformer.
- The **YD8044** has a power management system that ensures error-free switching of the outputs at all times. Therefore, loss of switching commands is effectively avoided.
- The solenoid address (turnout address) is configured simply by pressing the programming button. We have deliberately chosen to keep the configuration as simple as possible, which is why no further settings are required on the YD8044 for normal operation. Only a freely selectable solenoid address (turnout address) must be assigned as the start address. The YD8044 then automatically assigns the three subsequent solenoid addresses.
- When delivered, the **YD8044** is preset with the solenoid addresses 1-4.
- For control centres that can generate several protocols simultaneously, it is essential to ensure that the accessory addresses occupied by the **YD8044** are preset as **DCC addresses**.
- Alternatively, the **YD8044** can be conveniently configured via the "ES-PGM Link" connection. Please note that this requires either a programming module (YD 9100, YD9101) or a YaMoRC module with an "ES-IN Link" connection (e.g. YD6016LN-xx).  
By configuring via the "ES-Link" it is possible to:
  1. freely assign the switching addresses
  2. change the switching pulse duration
  3. adapt or make the address switching matrix and the inversion of the switching term.
- **Attention!** If a **firmware update** is carried out via "ES-Link", the current configuration of the **YD8044** should be saved in a freely selectable directory using the "Export data" function.

## Technical Data

Number of Outputs	4 outputs (short-circuit proof up to 3A)
Number of relays for switch polarisation	4 (Loadable with max. 3 A)
Digital Format	DCC
Address Area	1-2048
Load Capacity of a Single Output	5A
Load capacity of the switch polarisation per output	2,5 A
Input Voltage AC	Min. 10 VAC Max. 16 VAC
Input Voltage DC	Min. 12 VDC Max. 19 VDC
Housing Dimensions	84mm x 88mm x 22mm
Distance Between Holes	94.5mm, 42.5mm

## Mounting

The YD8044 is mounted via the four mounting holes on the side of the housing.

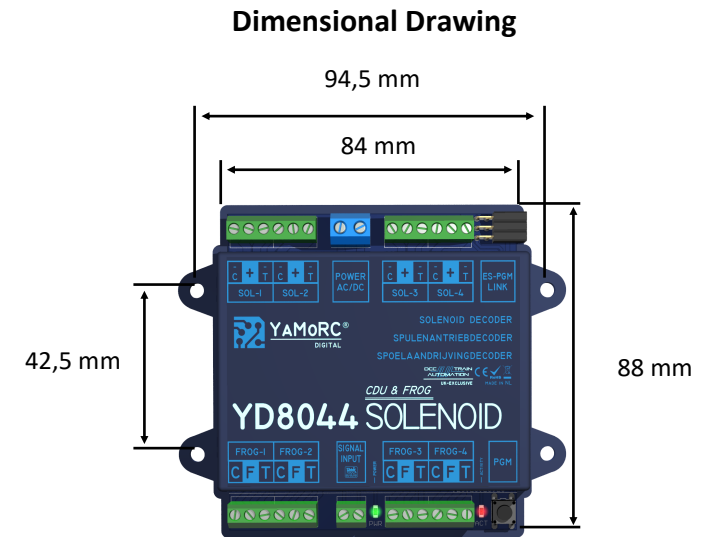

## Important Notes (Including Health & Safety):

- The YD8044 is intended exclusively for operation on an electric model railway.
- The YD8044 is **not** a toy and is therefore **not** suitable for children under 14 years of age.
- **Never** leave the YD8044 operating without your presence. Please disconnect the product before leaving it unattended.
- Voltage sources (power supplies, transformers, etc.) **must comply** with the current VDE/EN and CE standards.
- The voltage sources used (power supplies, transformers) **must comply** with Protection Class 2. Failure to comply may result in serious damage to the YD8044. The voltage sources must be marked with this symbol (illustrated below).



Further information on the **Protection Class 2** can be found here: <https://www.xppower.com/resources/blog/iec-protection-classes-for-power-supplies>

- VDirect voltage sources (**DC**) must not exceed a maximum power of **60W**.
- AC voltage sources (**AC**) must not exceed a maximum output current of **3A**.
- Voltage sources must be fused in such a way that a cable fire cannot occur in the event of a fault.
- AC transformers must **not** exceed a maximum output voltage of 16V AC.

The YD8044 internally rectifies AC voltage and always outputs DC voltage at the output terminals. It is essential to observe the polarity of the output terminals (- + -)!

- A common earth connection of different voltage sources or circuits is **not** permitted. This will destroy the YD8044.
- It is essential to ensure a sufficient wiring cross-section of the individual connections.
- The connection terminals for power are designed for a cross-section of 0.75 mm<sup>2</sup>. All other connection terminals are designed for a cross-section of 0.5 mm<sup>2</sup>.
- Connection work must always be carried out in a de-energised state. Disconnect or switch off power AC/DC and signal input.
- Discharging the internal power storage unit (CDU) takes approximately 10 minutes; all connection work may only be carried out after this time.
- The YD8044 must **never** be installed near sources of intense heat, such as radiators or places exposed to direct sunlight. Therefore, install the YD8044 in a place with sufficient ventilation to be able to dissipate the waste heat.
- The YD8044 is designed for dry indoor use only. Therefore, do **not** operate the YD8044 outdoors or in environments with extreme fluctuations in temperature and humidity.
- Do **not** attempt to open the YD8044. Improperly performed actions can lead to the destruction of the YD8044.

## Hardware Overview



1	<b>SOL-1</b>	<b>Connection first solenoid (turnout drive)</b> C connection solenoid item straight (green button) + common connection solenoid article T connection point machine bent (red button)
2	<b>SOL-2</b>	<b>Connection second solenoid (turnout drive)</b> C Connection solenoid item straight (green button) + common connection solenoid article T connection point machine bent (red button)
3	<b>Power AC/DC</b>	<b>Connection of the power supply for the solenoids</b> Input voltage AC (alternating voltage) min. 10 VAC max. 16 VAC / 3A Input voltage DC (direct voltage) min. 12 VDC max. 19 VDC /60W
4	<b>SOL-3</b>	<b>Connection third solenoid (turnout drive)</b> C connection solenoid item straight (green button) + common connection solenoid article T connection point machine bent (red button)

5	<b>SOL-4</b>	<b>Connection fourth solenoid (turnout drive)</b> C connection solenoid item straight (green button) + common connection solenoid article T connection point machine bent (red button)
6	<b>ES-PGM Link</b>	<b>Connection YaMoRC programming adapter</b> With the YaMoRC programming adapter, firmware updates and advanced programming can be carried out.
7	<b>FROG-1</b>	<b>Connection turnout polarisation first solenoid article</b> C curved rail of the turnout F cross frog of the turnout T Straight rails of the turnout
8	<b>FROG-2</b>	<b>Connection switch polarisation second solenoid article</b> C curved rail of the switch F cross frog of the turnout T straight rails of the turnout
9	<b>Connection DCC track signal (track voltage)</b>	
10	<b>Green LED</b>	3 states: 1. Heart-beat blinking - normal, idle operation, power present 2. High-speed blinking - idle operation, no power present 3. Dimmed intensity (usually increasing over time) - CDU is charging
11	<b>FROG-3</b>	<b>Connection of turnout polarisation third magnet article</b> C curved rail of the turnout F cross frog of the turnout T straight rails of the turnout
12	<b>FROG-4</b>	<b>Connection turnout polarisation fourth magnet article</b> C curved rail of the turnout F crossing frog of the turnout T straight rails of the turnout
13	<b>Red LED</b>	Activity Display one pulse of the LED, one solenoid address is controlled
14	<b>Programming switch</b>	

## Connecting the power supply

The YD8044 can be supplied with power either directly from the control panel or with a separate DC power supply (recommended) or AC transformer.

Power supply of the YD8044 directly via the digital central unit

**Attention:** If a 6016LN-xx is used to configure the YD8044 is used, the connection from Power AC/DC to the track out of the central unit or a booster must be disconnected.

Power supply of the YD8044 via a separate power pack (DC) or a transformer (AC) with min. 500 mA Output current

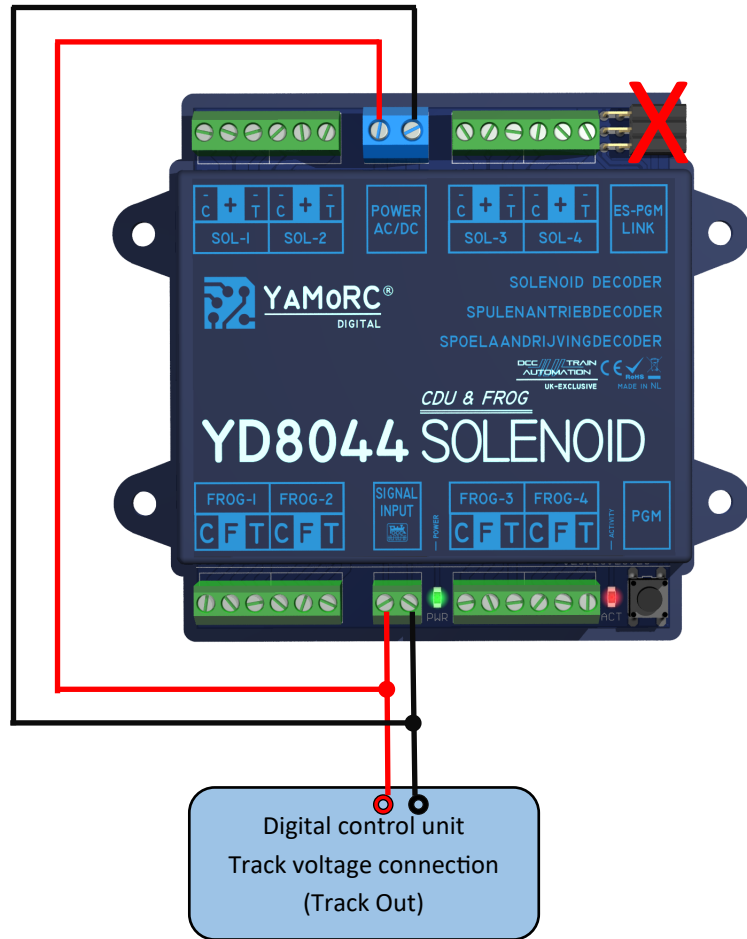

Voltage source  
Power supply unit  
(DC) 12-19 VDC  
  
Transformer  
(AC) 10- 16 VAC

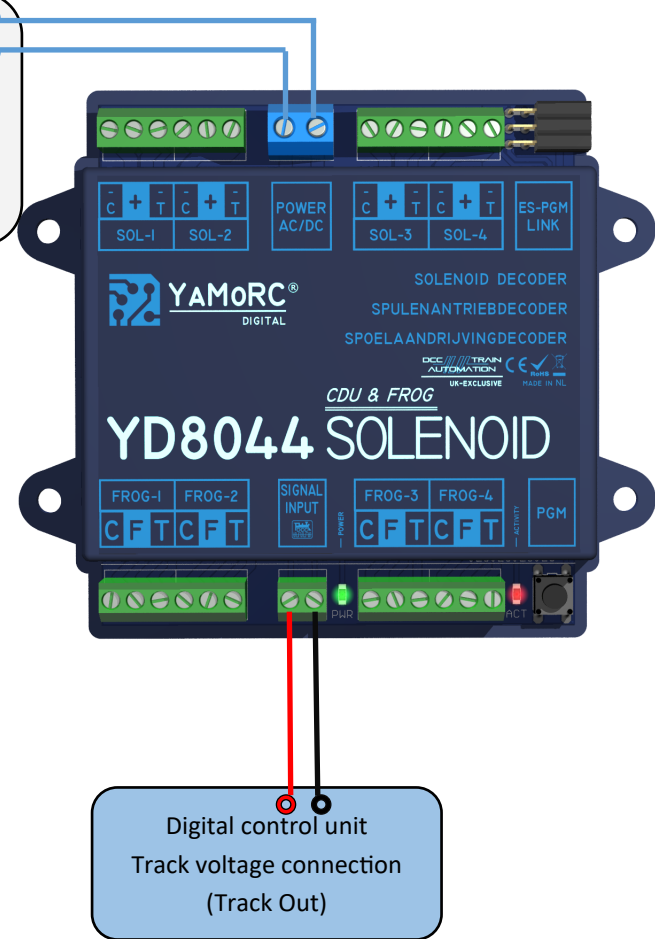

### Attention!

All connection work on the YD8008 must always be carried out in a de-energised state. Disconnect the power supply from the mains and **switch** off!

### Connection Examples for Different Solenoid Coil Drives

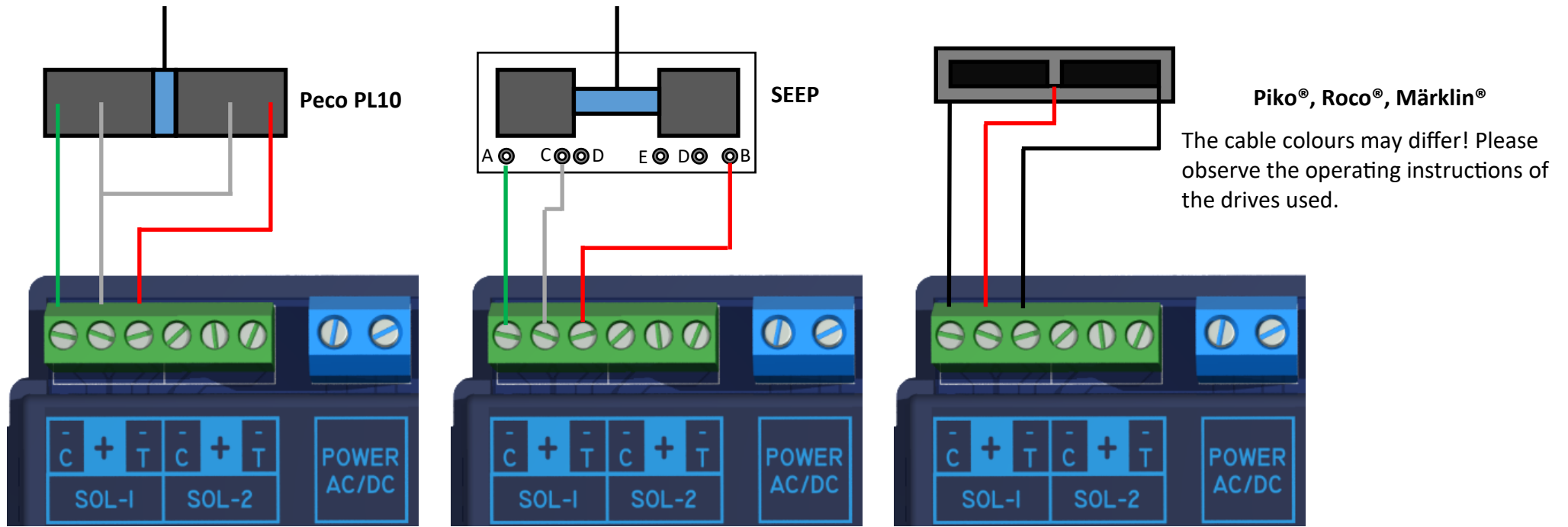

### Connection Example for Frog Polarisation

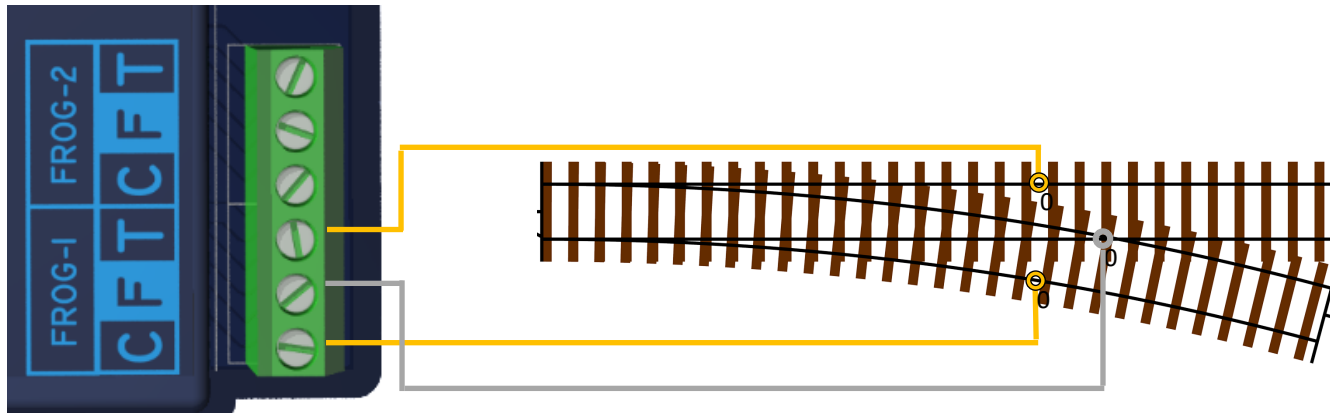

**Attention!**

All connection work on the YD8008 must always be carried out in a de-energised state. Disconnect the power supply from the mains and **switch** off!

## Connection example two-wire solenoid coil point machines e.g. Kato®

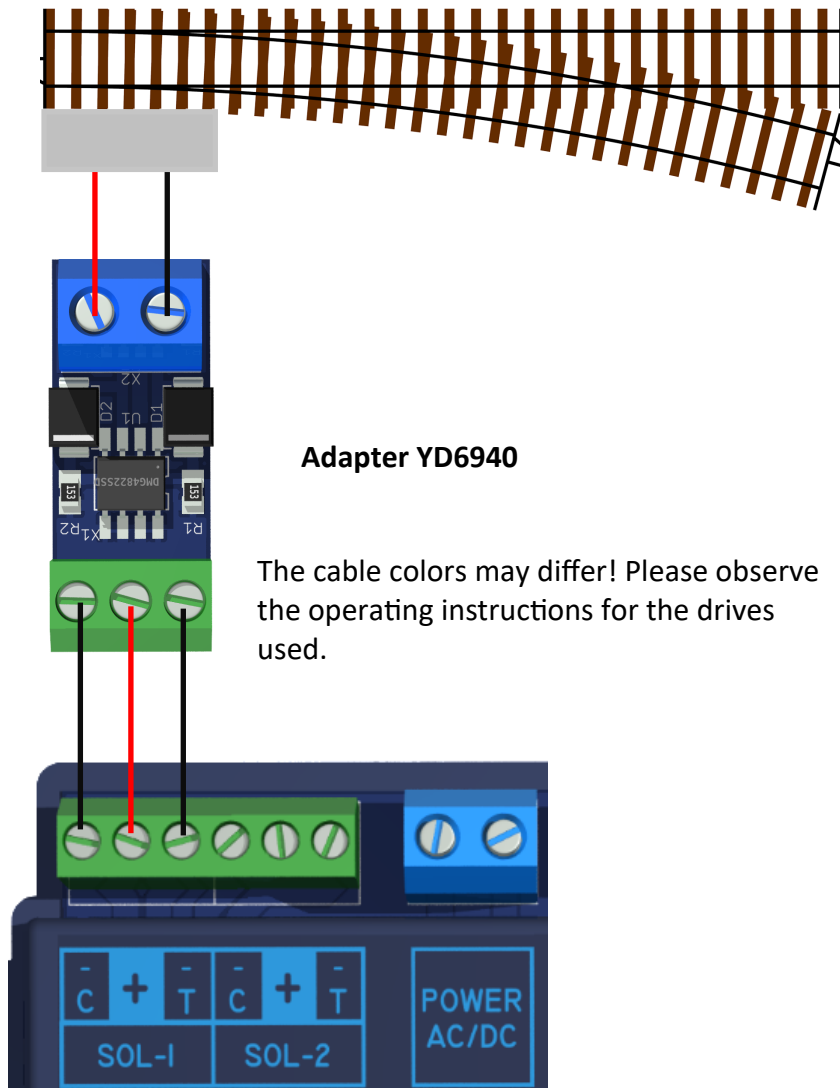

Adapter YD6940

The cable colors may differ! Please observe the operating instructions for the drives used.

### Attention!

All connection work on the YD8008 must always be carried out in a de-energised state. Disconnect the power supply from the mains and **switch** off!

## Configuring the start solenoid address (switch address)

YaMoRC has decided to make the configuration of the YD8044 as simple as possible. For this reason, the YD8044 does not have the CV programming that is used as industry standard. The YD8044 can reliably switch most solenoid coil drives "out of the box". These include drives from SEEP®, Peco®, Gaugemaster®, Roco®, Fleischmann®, Piko®, Märklin®, Viessmann® and all other standard solenoid coil drives.

If you have any questions, please contact our service department. We will certainly find a solution for you.

### Configuring the start solenoid address

1. Connect the power supply to the power input. 1
2. Connect the signal input to the track voltage output of the central unit. 2
3. Power supply via Power and switch on the control unit.
4. Call up the turnout control panel of the central unit and the turnout address to be assigned as the start address. Do not carry out a switching operation **yet!** (For the exact procedure on how to call up a turnout control panel, please refer to the documentation of your central unit or app).
5. Press the programming button to put the YD8044 into configuration mode. The red LED next to the button will light up continuously to indicate that the YD8044 is in configuration mode. 3
6. Press the desired turnout address to be used as the start address once on the turnout control panel of the central unit. The following solenoid addresses are assigned automatically. Thus, the YD8044 occupies four consecutive solenoid addresses. (For the exact procedure for switching a point address, please refer to the documentation of your control unit or app).
7. The assignment of the solenoid addresses is completed and the YD8044 automatically exits configuration mode. (The red LED next to the programming button goes out).

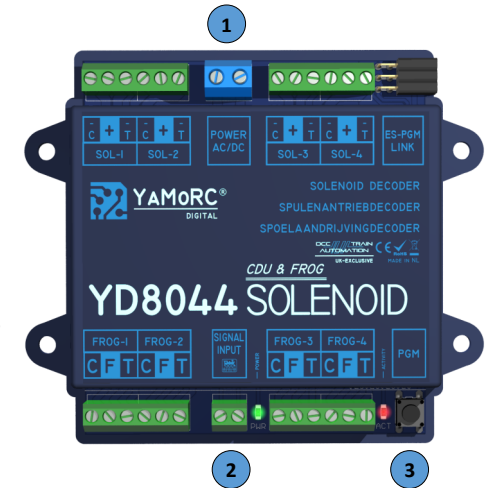

### Attention!

All connection work on the YD8008 must always be carried out in a de-energised state. Disconnect the power supply from the mains and **switch** off!

## Warranty

### 24 months warranty from date of purchase

Dear Customer,

Congratulations on your purchase from YaMoRC. YaMoRC's high quality products have been manufactured using modern manufacturing processes and have been subjected to careful quality control and tests.

Therefore, when purchasing a YaMoRC product, the company YaMoRC grants you a manufacturer's warranty of 24 months from the date of purchase in addition to the national warranty rights to which you may be legally entitled to, from your YaMoRC specialist dealer as contractual partner.

### Warranty conditions:

This warranty applies to all YaMoRC products purchased from a YaMoRC dealer. Warranty services are only provided if proof of purchase is presented. Proof of purchase is the purchase receipt from the YaMoRC specialist dealer. It is therefore recommended to keep your purchase receipt safe.

### Content of the guarantee/exclusions:

The warranty includes, at YaMoRC's discretion, the free repair or free replacement of the defective part, which can be proven to be due to design, manufacturing, material or transport faults. For this purpose, you must send the decoder to us properly stamped. Further claims are excluded.

### The warranty claims are void:

1. in the case of general wear and tear at expected locations (e.g. screw terminals).
2. in the case of modification of YaMoRC products with parts not approved by the manufacturer.
3. in the case of modification of parts, especially by opening the housing.
4. if the product is used for purposes other than those intended by the manufacturer.
5. if the instructions given by YaMoRC in the operating manual have not been thoroughly read by the user & risked mis-use of the product.

The warranty period is not extended by the repair or replacement delivery. Warranty claims can only be made to your dealer, enclosing any warranty



### **Drenth Design & Consulting B.V.**

Glazeniershorst 209

NL-7328 TJ APELDOORN

**Liability:** Drenth Design & Consulting B.V.

**Phone:** +31643392605

**E-Mail:** ddc@yamorc.com

**Directors:** Karst Drenth

**Trade register:** 72184728

**VAT No/Tax ID:** NL-859019901B01