

Sanremo _02

—

Coffee Machines

Opera 2.0 _06

Café Racer _16

F18 MB _26

F18 SB _30

D8 _34

Verona RS _48

Verona _52

Napoli _54

Torino _56

Zoe Competition _58

Zoe _60

Cube _62

You _68

—

Grinders

X-One _78

On demand _80

AllGround _84

THE BRAVE INSPIRE

PIONEERS OF A NEW VISION



A broad vision. A horizon defined by a high and ambitious goal, to be contemplated and then achieved, to be admired and eventually conquered.

Be inspired, take a deep breath then go:
start your adventure.

Because courage is not the absence of fear,
but the ability to conquer it.



SANREMO
COFFEEMACHINES

made in italy

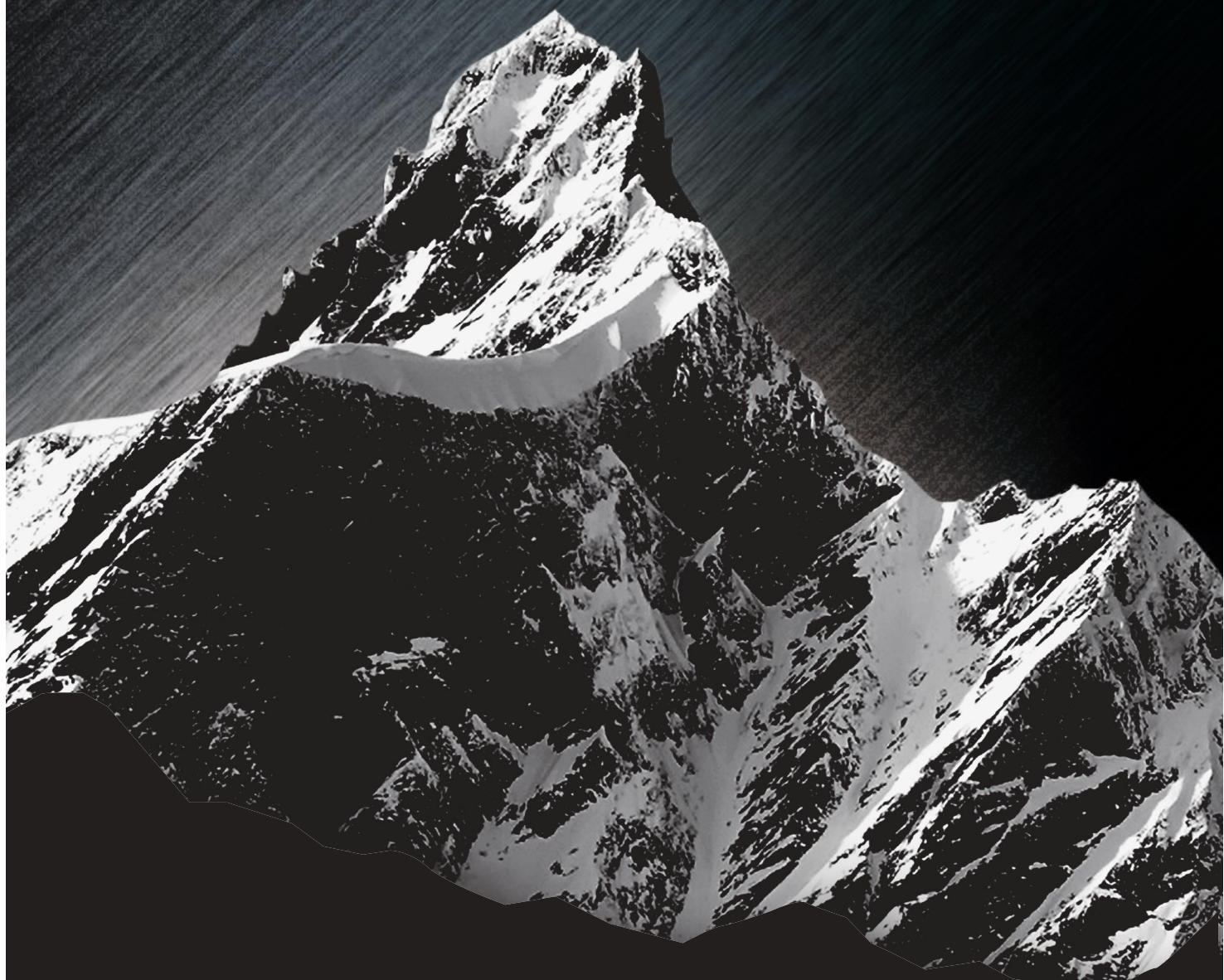

SANREMO, MORE THAN A COMPANY

A benchmark for innovation and excellence in espresso coffee machines production Made in Italy; an inspirational brand for coffee lovers who celebrate the art of coffee extraction.

This is Sanremo: A fusion of a strong production tradition and ambitious dreams. A winning combination that has given

the company international recognition and is now a point of reference in the coffee machine sector.

Our production department is second to none, our technological know-how, mixed with quality materials, workmanship and creativity.

An international research & development team, trained by the best in the coffee industry united with the same fighting spirit which Sanremo machines express.



Coffee Machines



Opera 2.0



Opera. The full story
Watch the video





Versions

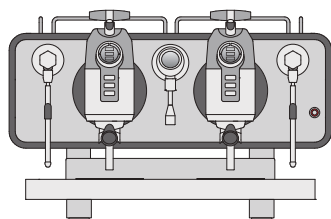

31" / 786 mm

2 group OP

- 2 steam taps
- 1 water tap
- 1 one-cup filter holder
- 2 two-cup filter holders

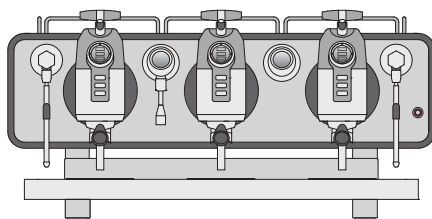

41" / 1040 mm

3 group OP

- 2 steam taps
- 1 water tap
- 1 one-cup filter holder
- 3 two-cup filter holders

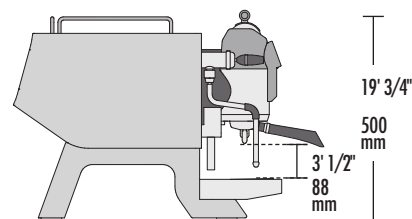

19' 3/4" / 507 mm

25' 2/3" / 653 mm

19' 3/4"

500 mm

3' 1/2"
88 mm

TALL VERSION

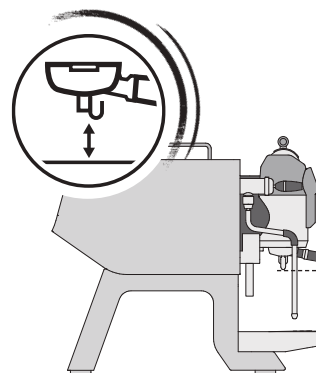

22' 1/4"

564 mm

6"
152 mm



Technical data		2 group	3 group
voltage	V	220-240 1N /	380-415 3N
max input boiler/steam boiler's resistor power	kW	7.7 / 3.5	8.3 / 3.5
		8.5 / 4.5	9.1 / 4.5
steam boiler services	lt	8	10
external pump power	kW	0.15	0.15
preheating boiler capacity	lt	2.8	2.8
preheating boiler resistance power	kW	1.5	1.5
cup-heater power	kW	0.20	0.25
units boiler capacity	lt	1.0	1.5
units boiler resistance power	kW	1.6	2.4
net weight	lb / kg	200 / 91	249 / 113
gross weight (with shipping crate)	lb / kg	308 / 140	375 / 170.5

MULTI-BOILER SYSTEM

High accuracy thermal stability thanks to the Sanremo multiboiler system with sophisticated electronic boards that continuously control temperature throughout all phases of extraction. Steam and coffee circuits work totally independent to maximize performance in every working condition (also under high workload).

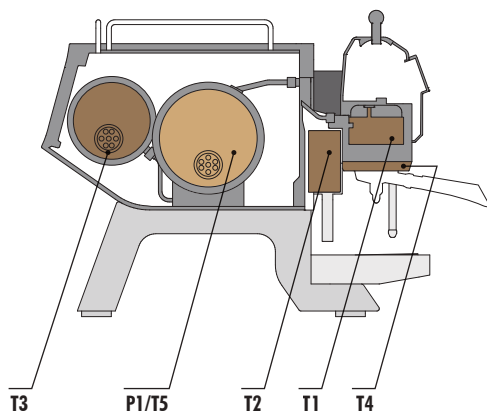



CDS SYSTEM

Maximum precision and full control on the three phases of coffee extraction

DOUBLE SELECTION BUTTONS

Easy-touch setting with 6 different profiles for individual groups

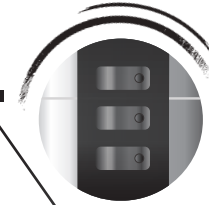

SMART LEVER

Coffee doses fast manual selection



POWER DRY STEAM

Low additional liquid during the milk steaming

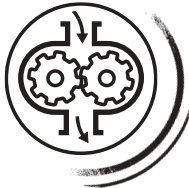

GEAR PUMP PERFORMANCE

High and constant pressure in all conditions



Opera. The Revolution
Link to the website

Characteristics



AISI 316L STEEL GROUPS WITH 22 lb / 10 kg PURE STEEL
Exclusive Sanremo design ensure exceptional thermal stability and maximum resistance to oxidation and lime scale.



AISI 316 STAINLESS STEEL FILTER HOLDER WITH "COMPETITION FILTER"*
Exclusive Sanremo design, with shape and volume designed to capture the best coffee aromas and fragrances.



AISI 316L STAINLESS STEEL FREE MOTION STEAM TAPS
Flexible control system for producing and dispensing steam.



AISI 316L STAINLESS STEEL STEAM WAND "COOL TOUCH"
Anti-burning feature even in conditions of prolonged use, fitted with "Latte Art"*** high-performance steam terminals.



CONTROL COFFEE DELIVERY SYSTEM (CDS)
Three phases extraction parameters full control (pre-infusion, infusion, post-infusion).



INDEPENDENT ADJUSTMENT OF THE PID INFUSION WATER TEMPERATURE
Precision setting (gradient $\pm 0.1^\circ\text{C}$ with measured constancy lower than 0.2°C).



INFUSION WATER DISPLAY
Indicates tea and herbal teas water brewing temperature. (In the two group it is shown with the steam boiler display)



STEAM BOILER DISPLAY
Indicates steam boiler temperature and pressure. (In the two group Opera it is shown with the infusion water display)



COFFEE UNIT SINGLE DISPLAY
Controls of all coffee extraction parameters.



MACHINE'S PROGRAMMING PARAMETERS DISPLAY
The internal display is a handy programming interface for the maintenance technician.



MIXED INFUSION HOT WATER FOR TEA AND HERBAL TEAS
Instantaneous mixing of fresh water and steam for a better chemical and organoleptic quality.

The Revolution

Be in control, express yourself



EVERYTHING UNDER CONTROL

System digital display to provide visibility of all working parameters

HEART OF STEEL

For maximum thermal stability:

- Groups in AISI 316L weight 22 lb / 10 kg each
- Filter holders AISI 316
- Boilers AISI 316



WI-FI CONNECTION



EASY APP

Tablet or smartphone barista's Webapp for setting parameters



GEAR PUMPS

Dedicated to each individual group, allow to change the pressure during infusion.



STEAM CONTROL ADJUSTABLE ELECTRONIC PRESSURE SWITCH

Sensor with 0.02 bar precision that allows the chosen pressure and steam in the boiler to be kept constant in all conditions of use.



PROGRAMMABLE CUP WARMER TEMPERATURE

Allows the cups to be kept at the optimum temperature in the most different climatic conditions.



EASY SERVICE

Fast access to the internal parts for quick and easy technical service.



AUTO-DIAGNOSIS, STATISTICAL DATA, SCHEDULED MAINTENANCE

Maintenance can be scheduled according to litres or number of coffees dispensed.



AUTO-ON, AUTO-OFF AND DAY-OFF FUNCTION

Programmable on-off timer for each day and/or daily timetables.



AUTOMATIC CLEANING CYCLE

Process for coffee groups cleaning.



ENERGY SAVING SYSTEM

Component insulation and smart electronics for maximum energy efficiency.



GROUP FLUSHING

With a simple pressure of the button a small quantity of water is dispensed to allow the group to be always clean.

Optional



* STAINLESS STEEL NAKED PORTAFILTERS



ENHANCED RESISTANCE



** HIGH POWER STEAMER TERMINAL (bigger holes diameter)



EXTERNAL VOLUMETRIC PUMP

Standard models

wide range of models

✓ **Opera Steel**
Standard back
panel: |BP1|

10



Choose the panel

to suit your style

SANREMO

OPERA^{2.0}
THE REVOLUTION

BP1 Etched crystal /
backlight

SANREMO

OPERA^{2.0}
THE REVOLUTION

BP2 Painted wood

SANREMO

OPERA^{2.0}
THE REVOLUTION

BP5 Black /
backlight



Back panel of each version can
be customized, with finishes that
complement your style and needs.

OPERA 2.0

THE REVOLUTION



✓ **Opera Black**
Standard back
panel: |BP5|



✓ **Opera White**
Standard back
panel: |BP2|



Everything in an App

app dedicated to parameter settings for tablet

12

(step A) GROUP SELECTION

(step B) PUSH / PULL LEVER SELECTIONS OF BUTTONS

(step C) SELECTIONS OF PROFILE BUTTONS
PUSH / dose 1,2,3
PULL / dose 4,5,6

(step D) TEMPERATURE REGULATION

(step E) DOSE REGULATION

(step F) INFUSION REGULATION

With the interface “Express yourself”, the barista has total control of the extraction phase of his coffee and can manage each dispensing parameter according to his experience and professionalism.

To configure and set all the parameters of the machine, a specific App has been designed, which runs on tablet.

The application “Express yourself” utilizes a graphic interface, it is both user friendly and intuitive. This interface allows the user to set each groups relative parameters accurately for the perfect extraction.

Upon choosing the group (step A) and assigned a configured profile (step B,C) will define the general parameters of extraction: temperature and doses (step D,E). At the end it is possible to adjust the parameters relative of the 3 extraction’s phases: pre-infusion, main infusion, post-infusion (step F).

For each group it is possible to set:

Temperature

- water temperature T2
- group temperature T3
- steam temperature T5 (unique boiler for all groups)

Dose

- weight of ground coffee
- water dose
- pump pressure
- coffee weight

Infusion

- timing
- pump pressure
- amount of water

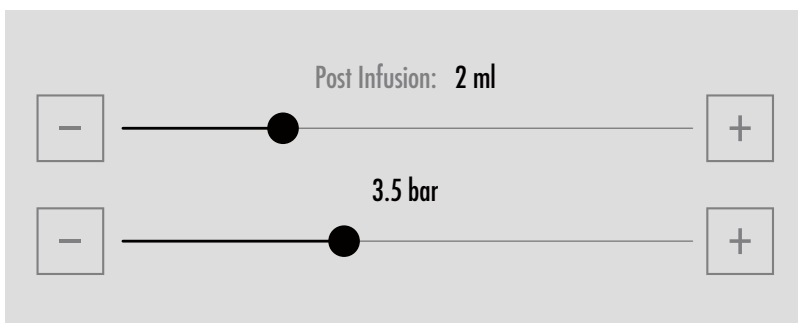
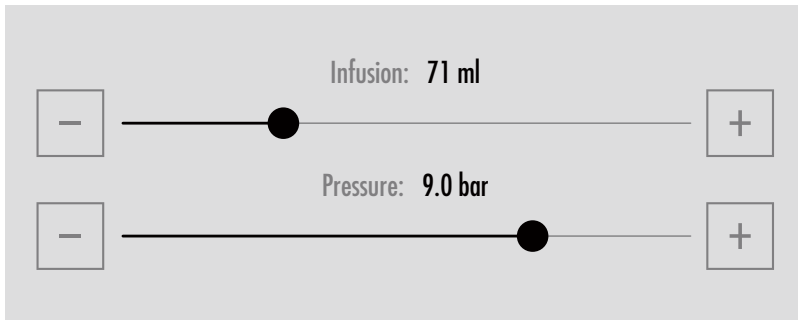
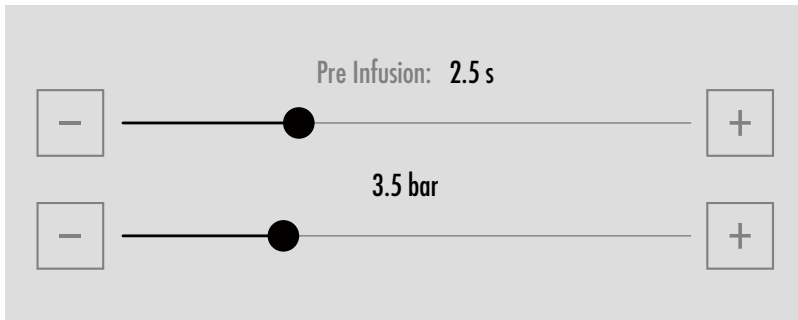







(step F)

Adjust the 3 extractions phases

This operation is simplified by the App. Everytime the user modify one of these parameter the software update automatically. What was set prior to the modification.



CONFIGURATIONS

-  **STANDARD**
-  **STRONG**
-  **BALANCED**
-  **SWEET & LIGHT**
-  ... N (set by the user)
-  ... N (set by the user)

It is possible to save and recall new configurations set by the user or the default ones, specifically designed to allow even the less experienced bartenders to obtain immediately excellent results in the cup.

Clicking in "save new configuration" you can save your perfect espresso dispensing menu and transfer it into another machine.

Opera wi-fi

simplify things



14

From today the Opera 2.0 is easier to handle, thanks to the *Sanremo Cloud* and *Webapp Expressyourself* interface, for an even easier and interactive using experience.

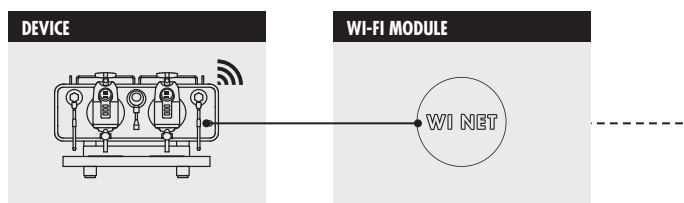
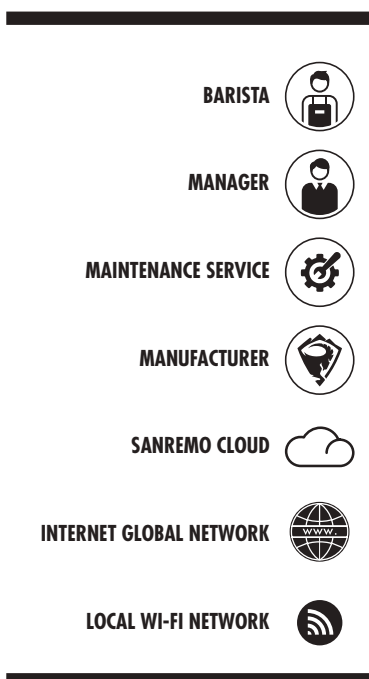

INTRANET (WI-FI LOCAL NET)

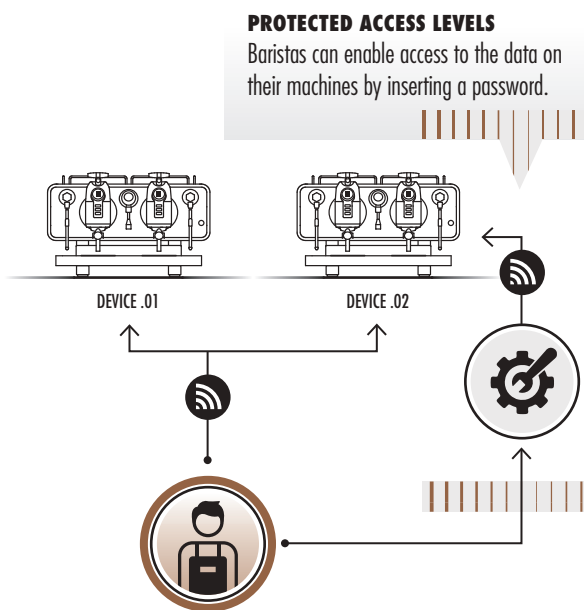

PLUS + (USING THE LOCAL WI-FI NETWORK)

- _ Reading and changing machine settings and parameters
- _ Consumptions analysis for a better stock management
- _ Meters reading of the coffee dispensed
- _ Saving, restoring and sharing of settings (recipes) on your machines

Data exchange can only be effective in the wi-fi range.



- Handling through Sanremo app, from smartphone, tablet, or pc, of all configuration parameters of the machine, without the need for physically being in front of it.
- Possibility of connecting multiple machines simultaneously for sharing, modifying, and setting of recipes and configurations.
- Simultaneous monitoring and handling of multiple machines by the same owner (e.g.: franchising in different locations).
- Statistical analysis of consumption, distribution, maintenance, configuration for all connected machines.
- Remote maintenance by the technician for updating, verification of the correct settings and parameters control.

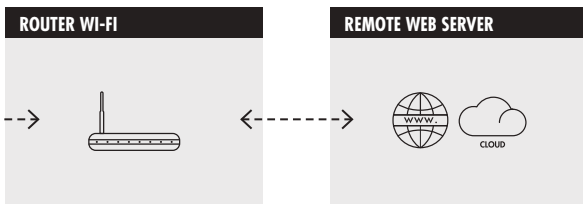

INTERNET (GLOBAL NET) / SANREMO CLOUD

PROTECTED ACCESS LEVELS
Baristas or Managers can enable access to the data of their machines by inserting a password to the service and / or to the manufacturer.

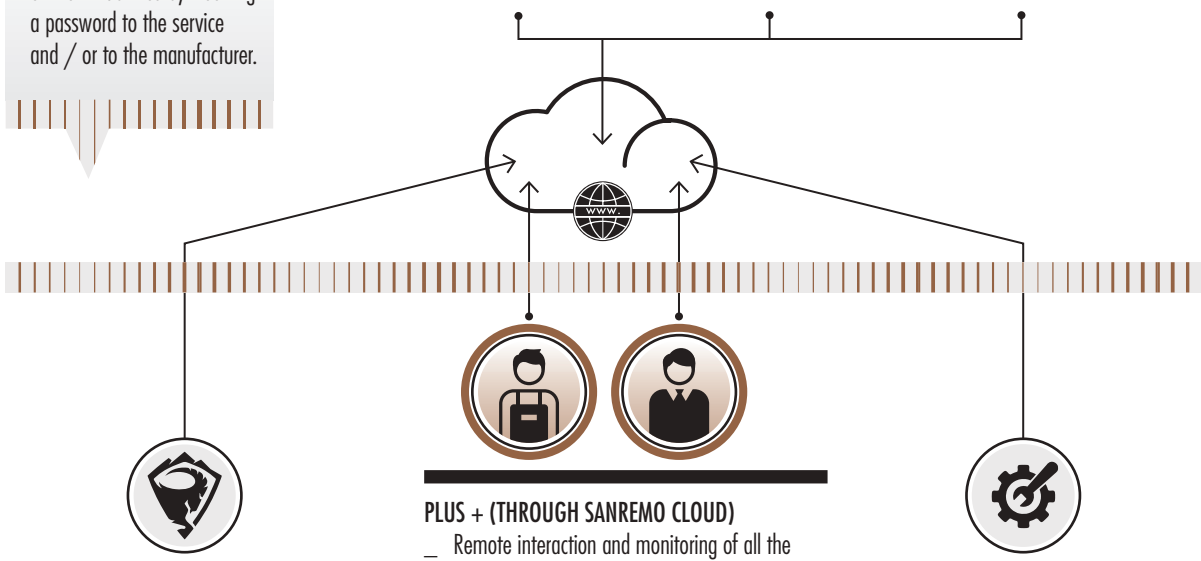
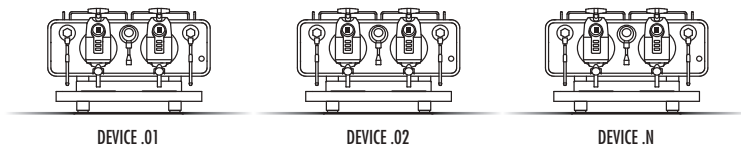

- PLUS + (ENABLING THE MANUFACTURER)**
- Sending of App updates to the machines
 - Sending new settings (recipes)
 - Clearer and faster data collection aimed to resolve any technical/constructive problems
 - Useful information for the improvement and evolution of the product
 - Direct and continuous contact with the manufacturer

- PLUS + (THROUGH SANREMO CLOUD)**
- Remote interaction and monitoring of all the functions and performances of the machine
 - Reading and changing of the machine settings
 - Display of historical usage data
 - Consumptions analysis for a better stock management
 - Meters reading of the coffee dispensed
 - Saving, restoring and sharing of settings (recipes) on your machines

- PLUS + (ENABLING THE SERVICE)**
- Immediate report of anomalies
 - Diagnosis and possible remote troubleshooting
 - Reduction of machine downtime
 - Logistic planning and organization of maintenance interventions

Café Racer





Versions

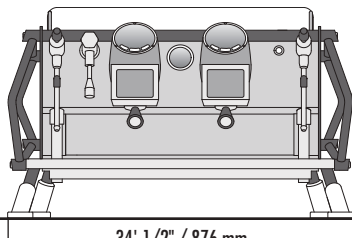

34' 1/2" / 876 mm

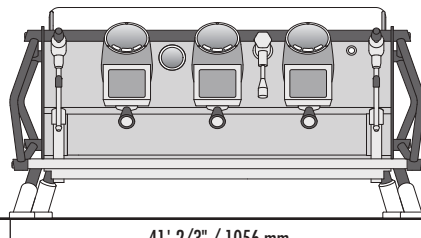

41' 2/3" / 1056 mm

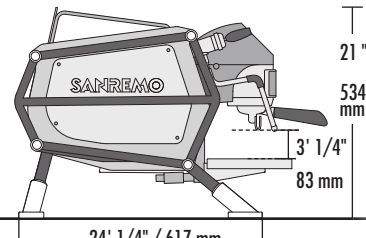

21" / 534 mm
3' 1/4" / 83 mm

24' 1/4" / 617 mm
27' 1/2" / 702 mm

2 group CR

- 2 steam taps
- 1 water tap
- 1 one-cup filter holder
- 2 two-cup filter holders

3 group CR

- 2 steam taps
- 1 water tap
- 1 one-cup filter holder
- 3 two-cup filter holders



MULTI-BOILER SYSTEM

Sanremo Café Racer multiboiler system ensures a new level of thermal precision thanks to the 4 points of temperature PID control.

Technical data		2 group	3 group
voltage	V	220-240 1N	380-415 3N
max input boiler/steam boiler's resistor power	kW	6.9 / 3.5	8.1 / 3.5
		7.6 / 4.5	8.4 / 4.5
steam boiler capacity	lt	8	10
external pump power	kW	0.160	0.160
preheating boiler capacity	lt	1.0	1.5
preheating boiler resistance power	kW	1.0	1.5
cup-heater power	kW	0.16	0.20
units boiler capacity	lt	1.0	1.5
units boiler resistance power	kW	1.6	2.4
net weight	lb / kg	214 / 97	265 / 120
gross weight (with shipping crate)	lb / kg	333 / 151	388 / 176

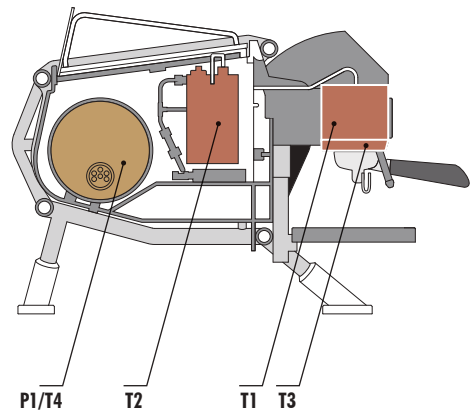



ENERGY SAVING SYSTEM

Component insulation and smart electronics for maximum energy efficiency



VOLUMETRIC PUMP PERFORMANCE

The unique 300 l/h pump guarantees constant pressure in all conditions of machine use

HIGH PERFORMANCE FLOWMETER VOLUMETRICS

For an accurate and precise coffee dose in the cup



POWER DRY STEAM

Low additional liquid during the milk steaming



EASY SERVICE

Fast access to the internal parts for quick and easy technical service



Café Racer, born to run
Link to the website

Characteristics



AISI 316L STEEL GROUPS WITH 17.6 lb / 8 kg PURE STEEL
Exclusive Sanremo design ensure exceptional thermal stability and maximum resistance to oxidation and lime scale.



AISI 316 STAINLESS STEEL FILTER HOLDER WITH "COMPETITION FILTER"*
Exclusive Sanremo design, with shape and volume designed to capture the best coffee aromas and fragrances.



AISI 316L STAINLESS STEEL FREE MOTION STEAM TAPS
Flexible control system for producing and dispensing steam.



AISI 316L STAINLESS STEEL STEAM WAND "COOL TOUCH"
Anti-burning feature even in conditions of prolonged use, fitted with "Latte Art"*** high-performance steam terminals.



PROGRAMMABLE ELECTRONIC PRE-INFUSION
Allows control with 0.1 second tolerance of the flow of water that wets the coffee bed, with programming of 4 different profiles for each group.



INDEPENDENT ADJUSTMENT OF THE PID INFUSION WATER TEMPERATURE
Precision setting (gradient $\pm 0.5^\circ\text{C}$ with measured constancy lower than 0.2°C).



SYSTEM DISPLAY
Visibility of all the machine functions: temperatures, pressures and levels.



COFFEE UNIT SINGLE DISPLAY
Control of all coffee extraction parameters.



MIXED INFUSION HOT WATER FOR TEA AND HERBAL TEAS
Instantaneous mixing of fresh water and steam for a better chemical and organoleptic quality.



HIGH PERFORMANCE VOLUMETRIC PUMP 300 l/h***
Pressure stability also with prolonged and contemporary use of more than one group.



HIGH PERFORMANCE FLOWMETER VOLUMETRICS
For an accurate and precise coffee dose in the cup.

Take a ride, explore it's soul



Quick setting
of the individual groups

EVERYTHING UNDER CONTROL

System digital display
to provide visibility of all
working parameters



HEART OF STEEL

For maximum thermal stability:

- Groups in AISI 316L, weight 17.6 lb / 8 kg each
- Portafilters AISI 316
- Boilers AISI 316

SOFT PRE-INFUSION

Flowactive System: for
precise control of the water
flow and pre-infusion time

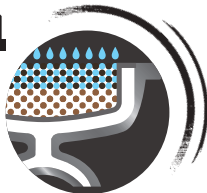

ADJUSTABLE HEIGHT WORK SURFACE

Innovative Sanremo "All in one"
suspension system that allows cups
of different shapes and heights
(adjustable from 3' 2/4" to 5' 3/4"
/ from 85 to 150 mm)



STEAM CONTROL ADJUSTABLE ELECTRONIC PRESSURE SWITCH

Sensor with 0.02 bar precision that
allows the chosen pressure and steam
in the boiler to be kept constant
in all conditions of use.



AUTO-DIAGNOSIS, STATISTICAL DATA, SCHEDULED MAINTENANCE

Maintenance can be scheduled according
to litres or number of coffees dispensed.



GROUP FLUSHING

With a simple pressure of the button
a small quantity of water is dispensed
to allow the group to be always clean.



PROGRAMMABLE CUP WARMER TEMPERATURE

Allows the cups to be kept at the optimum
temperature in the most different
climatic conditions.



AUTO-ON, AUTO-OFF AND DAY-OFF FUNCTION

Programmable on-off timer for
each day and/or daily timetables.

Optional



*
STAINLESS
STEEL NAKED
PORTAFILTERS



**
HIGH POWER
STEAMER
TERMINAL
(bigger holes diameter)



EXTERNAL
VOLUMETRIC
PUMP



ELECTRONIC AUTO-LEVEL

Through an electronic level probe
the boiler is automatically filled and
maintained to the right filling level.



AUTOMATIC CLEANING CYCLE

Process for coffee
groups cleaning.



ENHANCED
RESISTANCE



LED LIGHTING OF THE WORK AREA

Allows efficient working in any
condition of environmental lighting.



BOILER WATER REGENERATION

Ensures resetting of the optimum
chemical characteristics of the water
and correct mineralisation.

NAKED

- ✓ Transparent side and back panels

Available in 2 finishes:
black and steel, 
both available with some components*
in black or red.

● ●
* rings, bolts, feet, boiler insulation

20



FREEDOM

- ✓ Coloured side and back panels with the rear-lit logo

Available in 2 finishes:
black and steel, 
both available with some
components* in black or red.

● ●
* rings, bolts, feet



P1



P2



P3



P4



Welcome to the Custom world of the "Café Racer", huge creative potential and expression through customization. Some versions have become real icons. Chose your style and create your own unique Café Racer.

CUSTOM

Renegade



handmade finishes

- Dark green
- Oxidized copper
- Brown leather
- Polished brass
- Oxidized brass



_ White & Wood Standard

_ CUSTOM

22

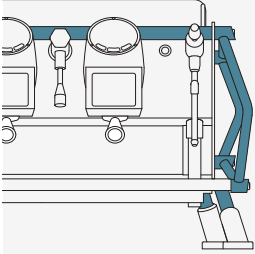

-  **Matt white**
-  **Natural oak**
-  **Stainless steel**
-  **Natural oak**

_ White & Wood Slim

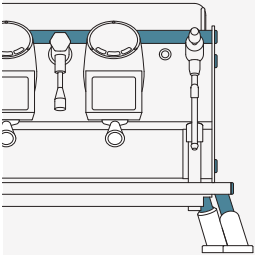

_ Racing

_ CUSTOM



-  **Gloss red**
-  **Matt white**
-  **Carbon**
-  **Stainless steel**

_ Dolomiti



-  **Matt black**
 -  **Black steel**
 -  **Black leather**
 -  **Stainless steel**
- hand-sewn*

Black & White

CUSTOM

24



— Matt white
● Stainless steel

Full White



_ Blue

_ CUSTOM



■ Matt blue

_ Fuchsia



■ Matt red

F18 MB





Versions

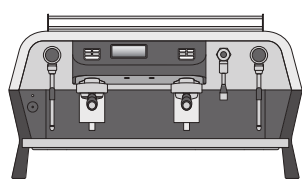

35' 1/2" / 901 mm

2 group

- 2 steam taps
- 1 water tap
- 1 one-cup filter holder
- 2 two-cup filter holders

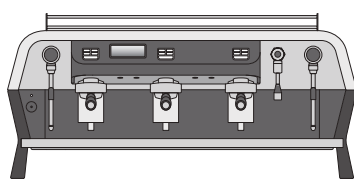

42' 1/4" / 1071 mm

3 group

- 2 steam taps
- 1 water tap
- 1 one-cup filter holder
- 3 two-cup filter holders

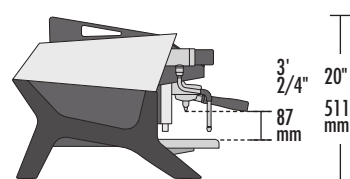

23' 1/4" / 589 mm

25' 1/2" / 647 mm

3' 2/4" / 87 mm

20" / 511 mm

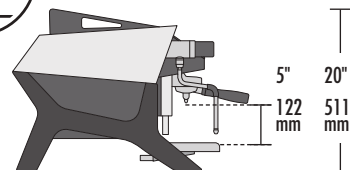
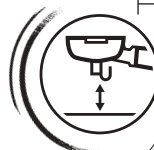

5" / 122 mm

20" / 511 mm



TALL VERSION

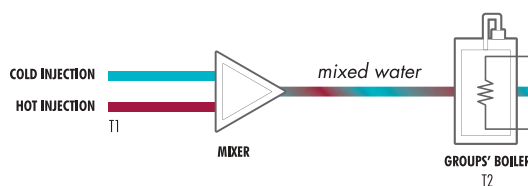

MULTI-BOILER SYSTEM

Each group has a dedicated boiler powered by preheated water thanks to the mixing of cold and hot water coming from the heat exchangers; the group is kept at the ideal temperature by a specific resistor, which ensure a perfect thermal regulation.



Technical data		2 group	3 group
voltage	V	220-240 1N / 380-415 3N	
max input boiler/steam boiler's resistor power	kW	5.4 / 3.5	6.1 / 3.5
		6.3 / 4.5	7.2 / 4.5
		7.3 / 5.5	8.2 / 5.5
steam boiler capacity	lt	8.6	10
pump power	kW	0.15	0.15
boiler capacity	lt	1	1.5
boiler element power	kW	1	1.5
cup-heater power	kW	0.20	0.25
net weight	lb / kg	182 / 82.5	222.5 / 101
gross weight (with shipping crate)	lb / kg	241.5 / 109.5	278 / 126

Colours

	Matte black	RAL 9005
	White Matte black	RAL 9003 9005
	Blue Matte black	RAL 5024 9005





QUICK STEAM COUPLING

The completely new half-turn knob with **INTEGRATED PURGE** function, allows extreme precision limiting physical stress

REALTIME STABILITY GROUP

Exclusive Sanremo design that allows an accurate maintenance of the set temperature





REALTIME STABILITY

Constancy in the electronic controlled temperature ($\pm 0.2\text{ }^{\circ}\text{C}$)



ENERGY SAVING SYSTEM

Component insulation and smart electronics for maximum energy efficiency



STAINLESS STEEL "COLD TOUCH"

Anti-burning feature fitted with "Latte Art" high-performance steam terminals



DIE-CAST ALUMINIUM LEGS

Machine support made in die-cast aluminium



OPERATION ALARM MANAGEMENT











Dedicated menu for malfunction and alarm records

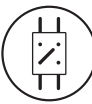

F18 MB
Link to the website



Characteristics

 <p>MIXED INFUSION HOT WATER FOR TEA AND HERBAL TEAS Immediate mixing of cold / hot water for a better chemical and organoleptic quality.</p>	 <p>INDEPENDENT REGULATION TEMPERATURE WATER COFFEE Maximum temperature precision and constancy of distribution.</p>	 <p>LED LIGHTING OF THE WORK AREA Allows efficient working in any condition of environmental lighting.</p>
 <p>STATIC RELAY BOILER TEMPERATURE Allows to regulate the temperature as accurately as possible.</p>	 <p>PROGRAMMABLE ELECTRONIC PRE-INFUSION Allows control with 0.1 second tolerance of the flow of water that wets the coffee bed, with programming of 4 different profiles for each group.</p>	 <p>AUTO-ON, AUTO-OFF AND DAY-OFF FUNCTION Programmable on-off timer for each day and/or daily timetables.</p>
 <p>STAINLESS STEEL COFFEE BOILER Guarantees excellent stability and thermal precision, associated with resistance to oxidation and limestone.</p>	 <p>AISI 316L STAINLESS STEEL STEAM WAND "COLD TOUCH" Anti-burning feature even in conditions of prolonged use, fitted with "Latte Art" high-performance steam terminals.</p>	 <p>ENERGY SAVING SYSTEM Component insulation and smart electronics for maximum energy efficiency.</p>
	 <p>PROGRAMMABLE CUP WARMER TEMPERATURE Allows the cups to be kept at the optimum temperature in the most different climatic conditions.</p>	 <p>REALTIME STABILITY GROUP Exclusive Sanremo design that allows a precise maintenance of the set temperature.</p>

In flight stability

Ready to take off

Control panel:

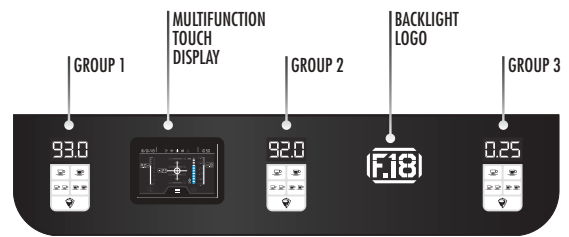

Keyboard 5 selections standard



TEMPERATURE AND EXTRACTION TIME

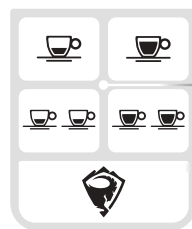

CONTINUOUS DELIVERY / GROUP FLUSHING

5/6 PROGRAMMABLE DOSES

Keyboard 7 selections optional



SOFT PRE-INFUSION
Flowactive System: for precise control of the water flow and pre-infusion time

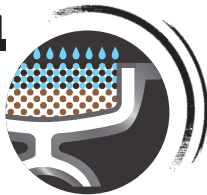

MULTIFUNCTION TOUCH DISPLAY

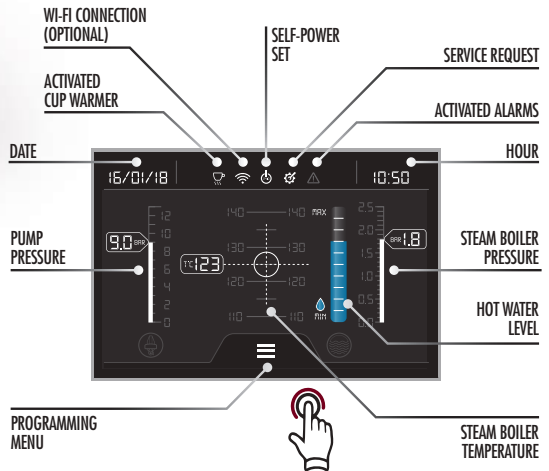

EASY SERVICE
Fast access to the internal parts for quick and easy technical service.



AUTOMATIC CLEANING CYCLE
Process for coffee groups cleaning.



HIGH PERFORMANCE VOLUMETRIC PUMP
Pressure stability also with prolonged and contemporary use of more than one group.



COMPETITION FILTERS
Exclusive Sanremo design, with shape and volume designed to capture the best coffee aromas and fragrances.



TEMPCONTROL
For a very-high thermal stability ($\pm 0.2^\circ\text{C}$).



GROUP FLUSHING
With a simple pressure of the button a small quantity of water is dispensed to allow the group to be always clean.



AUTOSTEAMER
Steam wand characterized by an electronic system that allows to mount and/or heat milk at the set temperature.



EXTERNAL VOLUMETRIC PUMP



HIGH POWER STEAMER TERMINAL
(bigger holes diameter)



NAKED PORTAFILTERS



STEAM CONTROL ADJUSTABLE ELECTRONIC PRESSURE SWITCH
Sensor with 0.02 bar precision that allows the chosen pressure and steam in the boiler to be kept constant in all conditions of use.

Optional

F18 SB





Versions

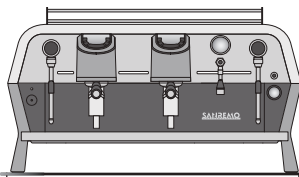

35' 2/3" / 907 mm

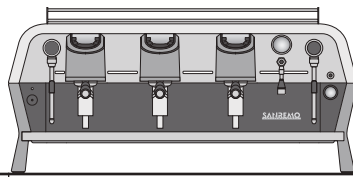

42' 1/3" / 1077 mm

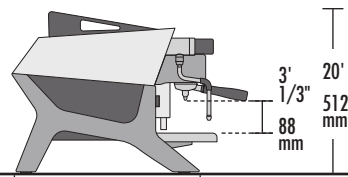

23' / 585 mm
25' 1/2" / 648 mm

3' 1/3" / 88 mm
20' / 512 mm

2 group

- 2 steam taps
- 1 water tap
- 1 one-cup filter holder
- 2 two-cup filter holders

3 group

- 2 steam taps
- 1 water tap
- 1 one-cup filter holder
- 3 two-cup filter holders

"TALL" VERSION

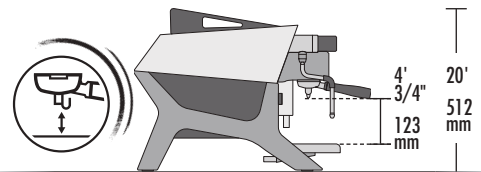

Colours

	Matte black Matte black	RAL 9004
	Matte black Matte white	RAL 9004 9003
	Matte black Brown	RAL 9004 8019
	Matte black Racing Red	RAL 9004 INVER 81784



Technical data		2 group	3 group
voltage	V	220-240 1N / 380-415 3N 50/60Hz	
max input boiler/steam boiler's resistor power	kW	3.2 / 2.7	5.65 / 5.1
		4.3 / 4.0	6.30 / 6.0
steam boiler capacity	lit	12	18
pump power	kW	0.15	0.15
cup-heater power	kW	0.20	0.25
net weight	lb / kg	172 / 78	211.5 / 96
gross weight (with shipping crate)	lb / kg	231.5 / 105	267 / 121

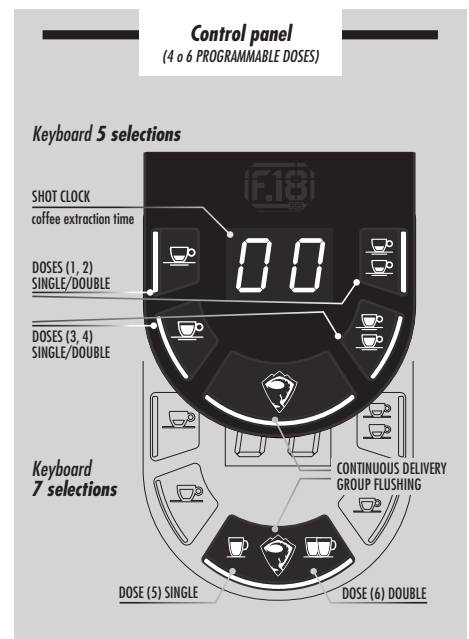

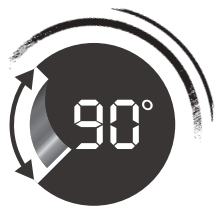

QUICK STEAM COUPLING

The completely new half-turn knob with **INTEGRATED PURGE** function, allows extreme precision limiting physical stress



ENERGY SAVING SYSTEM

Component insulation and smart electronics for maximum energy efficiency



DIE-CAST ALUMINIUM LEGS

Machine support made in die-cast aluminium

GROUP SR 61

Chromed brass grouphead with thermosiphonic circulation system optimized to maintain the ideal coffee extraction temperature

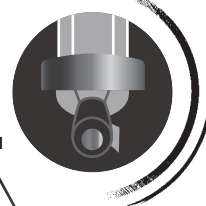

F18 SB
Link to the website

Characteristics



PRESSURE GAUGE

Allows to monitor the inlet and pump pressure during extraction.



ELECTRONIC AUTO-LEVEL

Through an electronic level probe the boiler is automatically filled and maintained to the right filling level.

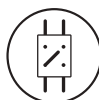

STATIC RELAY BOILER TEMPERATURE

Allows to regulate the temperature as accurately as possible thanks to the PID algorithm.



DIE-CAST ALUMINIUM LEGS



MULTIFUNCTION DISPLAY

Allows to monitor the right functioning of the machine and to program the main functions.



PROGRAMMABLE ELECTRONIC PRE-INFUSION

Allows control with 0.1 second tolerance of the flow of water that wets the coffee bed, with programming of 4 different profiles for each group.



HIGH PERFORMANCE VOLUMETRIC PUMP

Pressure stability also with prolonged and contemporary use of more than one group.



GROUP FLUSHING

With a simple pressure of the button a small quantity of water is dispensed to allow the group to be always clean.



GROUP SR 61

Chromed brass grouphead with thermosiphonic circulation system optimized to maintain the ideal coffee extraction temperature.



CUP WARMER

Dedicated resistor to keep all the cups at the optimal temperature. Power level programmable by user.







AUTOMATIC CLEANING CYCLE

Process for coffee groups cleaning. Cleaning cycles number programmable.



AUTOSTEAMER

-  FOAMING
-  STEAMING
-  AUTOMATIC CLEANING
-  HOT WATER



Autosteamer Version

MULTIFUNCTION DISPLAY

ECO MODE

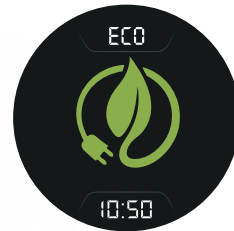

IDLE MODE - TEMPERATURE

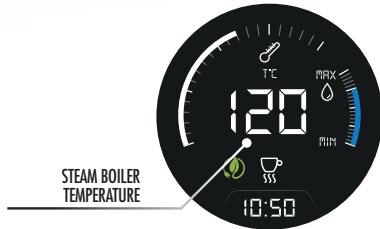

STEAM BOILER TEMPERATURE

FUNCTIONS

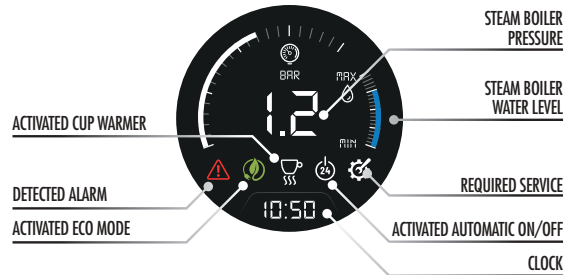

STEAM BOILER PRESSURE

STEAM BOILER WATER LEVEL

REQUIRED SERVICE

ACTIVATED AUTOMATIC ON/OFF

CLOCK

ACTIVATED CUP WARMER

DETECTED ALARM

ACTIVATED ECO MODE

Optional



ENERGY SAVING SYSTEM
Component insulation and smart electronics for maximum energy efficiency.



MIXED INFUSION HOT WATER FOR TEA AND HERBAL TEAS
Immediate mixing of cold / hot water for a better chemical and organoleptic quality.



AUTO-ON, AUTO-OFF AND DAY-OFF FUNCTION
Programmable ON-OFF/ON-ECO timer for each day and/or daily timetables.



EASY SERVICE
Fast access to the internal parts for quick and easy technical service.



AUTOSTEAMER
Steam wand characterized by an electronic system which allows to froth milk and heat up beverages at a programmable temperature, different for every single function. Automatic cleaning cycle is included.



EXTERNAL VOLUMETRIC PUMP



COMPETITION FILTERS
Exclusive Sanremo design, with shape and volume designed to capture the best coffee aromas and fragrances. Exclusive Sanremo design.



AISI 316L STAINLESS STEEL STEAM WAND "COLD TOUCH"
Anti-burning feature even in conditions of prolonged use, fitted with "Latte Art" high-performance steam terminals.



NAKED PORTAFILTERS



PAYMENT SYSTEM
RS-232 communication protocol to manage cash register systems.



LED LIGHTING OF THE WORK AREA
Allows efficient working in any condition of environmental lighting.



ENHANCED RESISTANCE



Platform

03



**GAME
CHANGER**



The **D8** is a innovative modular platform of professional espresso coffee machines, characterised by a single boiler configuration that can be customised according to the demands and needs of baristas and coffee roasters alike.

D8



_ Platform
game changer

D8 **PRO**

The **D8 PRO** is a special platform configuration in which aesthetic and technological components upgrade the performance level from that of the basic model.



The new single boiler platform. *Link to the video*



D8 | D8 PRO



38 Versions D8 and D8 PRO

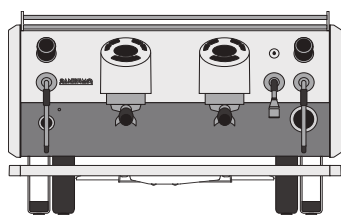

807 mm

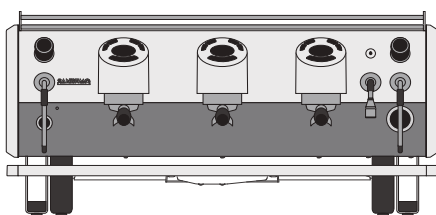

1037 mm

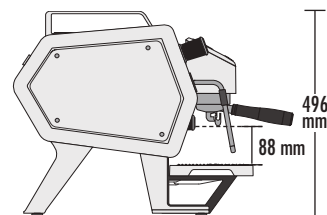

450,8 mm

554 mm

496 mm

88 mm

2 D8 groups

- 2 steam taps
- 1 water tap
- 1 filter holder one cup
- 2 filter holders two cups

3 D8 groups

- 2 steam taps
- 1 water tap
- 1 filter holder one cup
- 3 filter holders two cups



Technical data		2 groups	3 groups
voltage	V	220-240 1N / 380-415 3N	
cup heating plate dimensions	cm ²	1947	2547
steam boiler capacity	lt	7	10
exchanger/coffee boiler capacity	lt	0.3	
net weight	lb / kg	135.6 / 61.5	157.6 / 71.5
gross weight (with packaging)	lb / kg	187.4 / 85	209.4 / 95
max input boiler / steam boiler's resistor power	kW	4.2 / 3.5	5.7 / 4.5
		5.4 / 4.5	6.9 / 5.5
cup heating plate heating element power (optional)	kW	0.2 / 0.25	
pump power	kW	0.25	

VERSION D8 and D8 PRO "TALL"

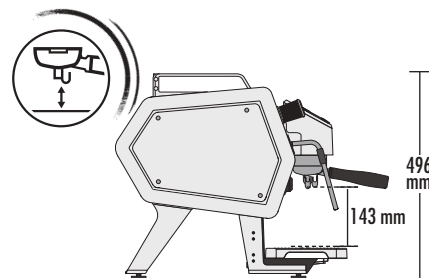

496 mm

143 mm

PUSH-BUTTON PANEL OF D8 AND D8 PRO

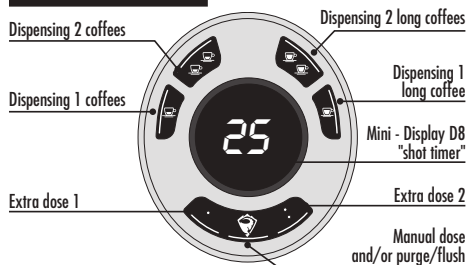

FUNCTIONS D8 PRO DISPLAY

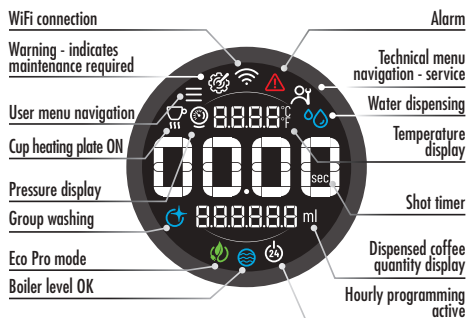

Performance





ENERGY SAVINGS

Component insulation and intelligent electronics management for maximum energy efficiency

PROGRAMMABLE PRE-INFUSION FUNCTION

For precise control of pre-infusion time

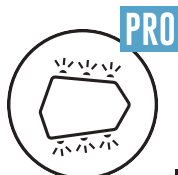

SIDE BACK-LIGHTING

Diffused LED light to enhance the personality of the machine (optional requiring side panels)



FAST MAINTENANCE

Easy access to internal parts for simplified servicing

PROGRAMMABLE STEEL BOILER AND TEMPERATURE CONTROL

Set up digitally your AISI 316L boiler at 1.0/1.2/1.4 bar

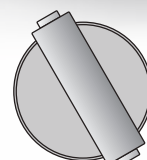

Characteristics



DUAL-READING PRESSURE GAUGE

Enables simultaneous control of line pressure, boiler pressure and coffee brewing pressure.



ELECTRONIC AUTOLEVEL

By means of an electronic level probe, the boiler is automatically filled and maintained at the correct level.

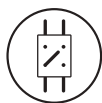

STATIC BOILER TEMPERATURE RELAY

Enables the desired temperature to be adjusted with the maximum precision.



SHOT TIMER

For precise and reliable coffee brewing timing.



MULTIFUNCTION SCREEN

Enables the correct operation of the machine to be monitored and the main functions to be programmed.



PRE-INFUSION

Pre-infusion function activable by user (programmable on PRO).



AUTO-ON, AUTO-OFF AND DAY-OFF FUNCTION

Programmable on-off timer on a single day and/or daily schedule.



RING GROUP

Chromed brass group ring electronically controlled for maintaining the ideal extraction temperature.



AUTOMATIC CLEANING CYCLE

Coffee group cleaning process and programmable number of washing cycles.



GROUP FLUSHING

With a simple push of the button, a small amount of water is dispensed to ensure that the group is always clean.



HIGH-PERFORMANCE VOLUMETRIC PUMP

Constant pressure even with prolonged and simultaneous use of several functions and groups.

Performance

make your move



WI-FI CONNECTION



EASY APP

"My Sanremo" smartphone app for setting parameters

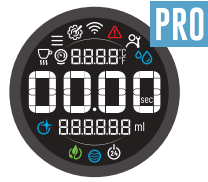

PRO

LCD COLOUR DISPLAY

Makes it possible to monitor the correct operation of the machine and program the main functions



D8

SHOT TIMER

For precise and reliable coffee dispensing timing

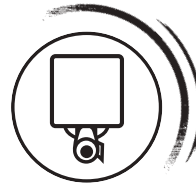

DIGITALLY PROGRAMMABLE GROUP TEMPERATURE

Setting from 90° to 98° from push-button panel

PRO

QUICK SETTING OF THE INDIVIDUAL GROUPS



LED WORK SURFACE LIGHTING

It allows to work effectively regardless of the lighting performance in the room (optional)

Optional



AISI 316L STAINLESS STEEL "COLD TOUCH" STEAM WANDS

Non-scalding, high-performance "Latte Art" steam terminals.

Standard options on the D8 PRO



LED-LIT WORKING AREA

It allows to work effectively regardless of the lighting performance in the room.

Standard options on the D8 PRO



HOT BLENDED INFUSION WATER FOR TEA AND HERBAL TEAS

Instant mixing of fresh water/hot water with adjustable temperature.

Standard options on the D8 PRO



PRO

LIGHTING PRO



COMPETITION FILTERS

Designed in shape and volume to best capture the aromas and fragrances of the coffee. Exclusive Sanremo design.



CASH ACCOUNT

RS-232 communication to credit management devices to enable dispensing.



IoT

App and cloud connection for machine control.



PRO

LEATHER SIDE PANELS



AESTHETIC SIDE PANELS

Available in different finishes.



CUP HEATING PLATE

Programmable dedicated heating element to obtain cups at the optimum temperature.



ENHANCED HEATING ELEMENT



EXTERNAL VOLUMETRIC PUMP



NAKED PORTAFILTERS

Style

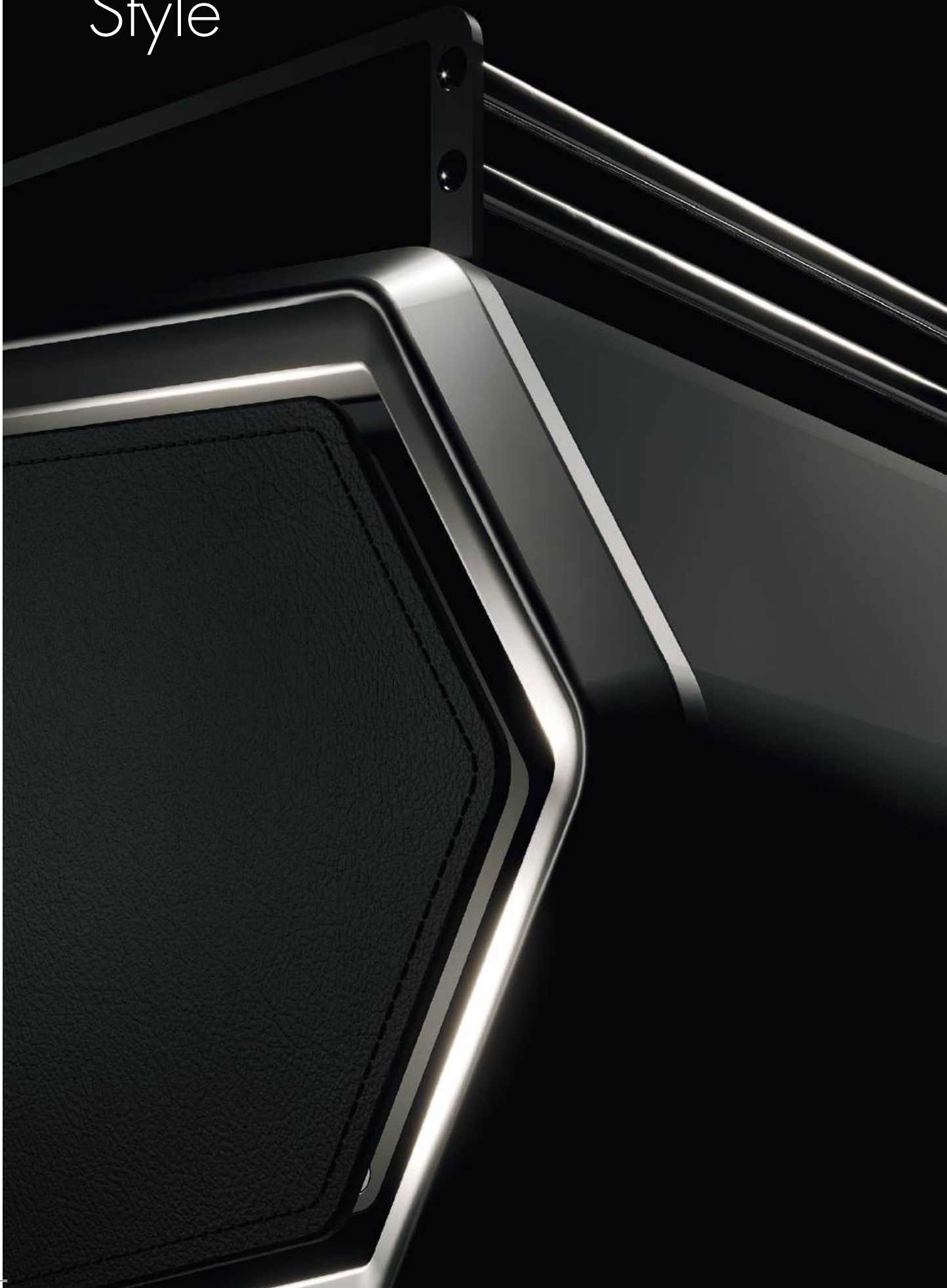

Style configuration



Stainless Steel

D8 D8 PRO



Stainless Steel

✓ **D8 / D8 PRO**
Stainless Steel

Decorative cover, back panel,
side panels: *stainless steel*
Edges: *chromed (E1)*



Black & Steel

✓ **D8 / D8 PRO**
Black&Steel

Decorative cover, back panel,
side panels: *stainless steel*
Edges: *varnished matt black*
RAL 9005 (E2)



_ Style configuration

Optional side panels

08

44



✓ **D8_Total Black**

Decorative cover, back panel,
inner side panels and edges:
matt black RAL 9005

Optional:
Side panels in matt black
steel RAL 9005 (P2)



✓ **D8_Black&White**

Decorative cover, back panel
and inner side panels:
matt white RAL 9003
Edges: matt black RAL 9005

Optional:
Side panels in matt white
steel RAL 9003 (P1)



✓ **D8_Total White**

Decorative cover, back panel
and inner side panels:
matt white RAL 9003
Edges: glossy white RAL 9003

Optional:
Side panels in matt white
steel RAL 9003 (P1)



✓ **D8 PRO_Total Black**

Decorative cover, back panel,
inner side panels and edges:
matt black RAL 9005

Optional:
Side panels in matt black
steel RAL 9005 (P2)
Black leather side panels (P4L)



✓ **D8 PRO_Black&White**

Decorative cover, back panel
and inner side panels:
matt white RAL 9003
Edges: matt black RAL 9005

Optional:
Side panels in matt white
steel RAL 9003 (P1)
White leather side panels (P3L)



✓ **D8 PRO_Total White**

Decorative cover, back panel,
inner side panels:
matt white RAL 9003
Edges: glossy white RAL 9003

Optional:
Side panels in matt white
steel RAL 9003 (P1)
White leather side panels (P3L)

_ Style configuration

Optional side panels

D8

Champagne

46



✓ D8 Champagne

Decorative cover, back panel
and edges: **white RAL 9003**
Inner side panels: **Champagne**

Optional:
Champagne steel side panels (P5)



✓ D8 Copper Gold

Decorative cover, back panel
and edges: **black RAL 9005**
Inner side panels: **Copper Gold**

Optional:
Copper Gold steel side panels (P6)



D8^{PRO}



✓ D8 PRO Champagne

Decorative cover, back panel
and edges: **white RAL 9003**
Inner side panels: **Champagne**

Optional:
Champagne steel side panels (P5)
White leather side panels (P3L)

47



Copper Gold



✓ D8 PRO Copper Gold

Decorative cover, back panel
and edges: **black RAL 9005**
Inner side panels: **Copper Gold**

Optional:
Copper Gold steel side panels (P6)
Black leather side panels (P4L)



Verona RS





Versions

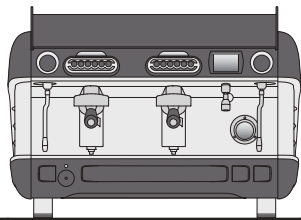

32' 1/4" / 818 mm

2 group RS

- 2 steam taps
- 1 water tap
- 1 one-cup filter holder
- 2 two-cup filter holders

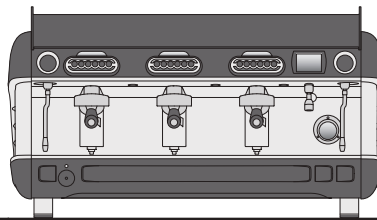

41' 1/4" / 1048 mm

3 group RS

- 2 steam taps
- 1 water tap
- 1 one-cup filter holder
- 3 two-cup filter holders

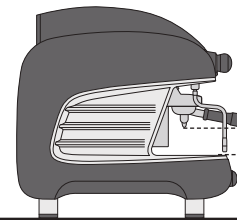

18' / 459 mm
23' 1/2" / 599 mm

3' 1/4" / 83 mm
23' 1/4" / 588 mm

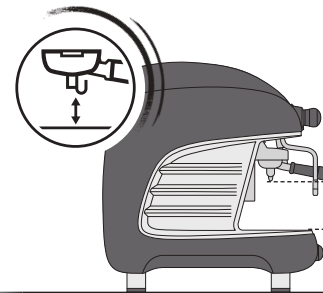

5' 3/4" / 140 mm
25' 3/4" / 652 mm

TALL VERSION

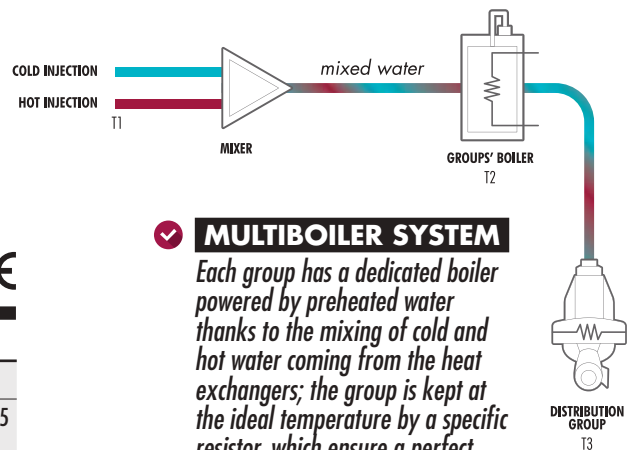

MULTIBOILER SYSTEM

Each group has a dedicated boiler powered by preheated water thanks to the mixing of cold and hot water coming from the heat exchangers; the group is kept at the ideal temperature by a specific resistor, which ensure a perfect thermal regulation.



Technical data		2 group	3 group
voltage	V	220-240 1N	380-415 3N
max input boiler/steam boiler's resistor power	kW	5.3 / 3.5	6.0 / 3.5
steam boiler capacity	lt	8.6	10
pump power	kW	0.2	0.2
RS boiler capacity	lt	1	1.5
RS boiler element power	kW	1	1.5
cup-heater power	kW	0.20	0.25
net weight	lb / kg	150 / 68	187 / 85
gross weight (with shipping crate)	lb / kg	163 / 74	200 / 91

Colours

	Black	RAL 9005
	White	RAL 1013
	Red	RAL 3011

**RS GROUP**

Exclusive Sanremo design that allows an accurate maintenance of the set temperature

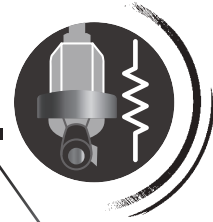
**REALTIME STABILITY**

Constancy in the electronic controlled temperature ($\pm 0.2\text{ }^{\circ}\text{C}$)

**PRE-INFUSION SYSTEM**

Enabled pre-infusion start&stop for each group

**STAINLESS STEEL "COLD TOUCH"**

Anti-burning feature fitted with "Latte Art" high-performance steam terminals



Verona RS
Link to the website

Characteristics

MIXED INFUSION HOT WATER FOR TEA AND HERBAL TEAS
Immediate mixing of cold / hot water for a better chemical and organoleptic quality.



ELECTRONIC AUTO-LEVEL
Through an electronic level probe the boiler is automatically filled and maintained to the right filling level.

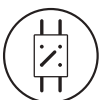

STATIC RELAY BOILER TEMPERATURE
Allows to regulate the temperature as accurately as possible.



STAINLESS STEEL COFFEE BOILER
Guarantees excellent stability and thermal precision, associated with resistance to oxidation and limestone.



INDEPENDENT REGULATION TEMPERATURE WATER COFFEE
Maximum temperature precision and constancy of distribution.



PRE-INFUSION SYSTEM
Enabled pre-infusion start&stop for each group.



AISI 316L STAINLESS STEEL STEAM WAND "COOL TOUCH"
Anti-burning feature even in conditions of prolonged use, fitted with "Latte Art" high-performance steam terminals.



PROGRAMMABLE CUP WARMER POWER
Electronic programmable cup warmer to keep cups warmed at the right temperature.



LED LIGHTING OF THE WORK AREA
Allows efficient working in any condition of environmental lighting.



AUTO-ON, AUTO-OFF AND DAY-OFF FUNCTION
Programmable on-off timer for each day and/or daily timetables.



DOUBLE READING GAUGE
Allows to control at the same time the boiler pressure and the distribution pressure.

Realtime Stability

A sprint of technology



ENERGY SAVING SYSTEM

Component insulation and smart electronics for maximum energy efficiency

Single group display:

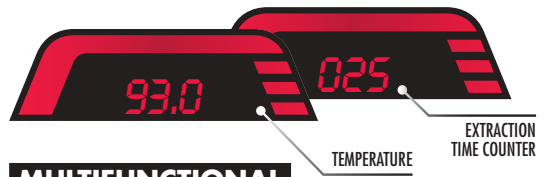

MULTIFUNCTIONAL DISPLAY

Touch display:

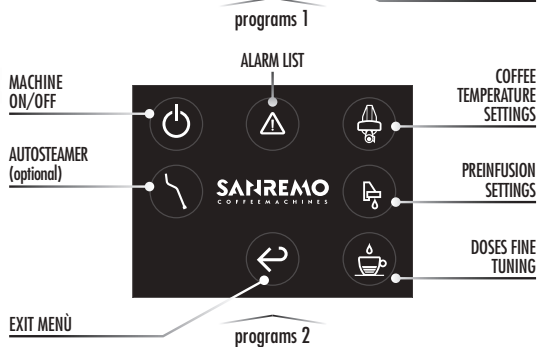
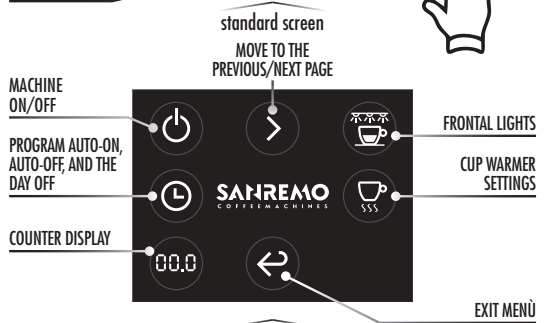
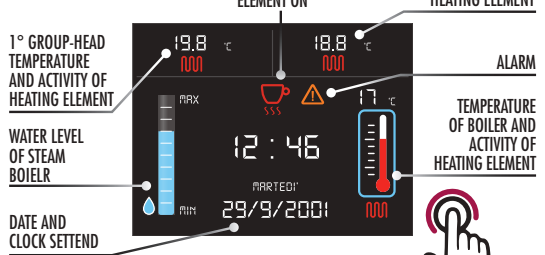

ENERGY SAVING SYSTEM
Component insulation and smart electronics for maximum energy efficiency.

RS GROUP
Exclusive Sanremo design that allows a precise maintenance of the set temperature.

EASY SERVICE
Fast access to the internal parts for quick and easy technical service.

CLEANING CYCLE
Process for coffee groups cleaning.

HIGH PERFORMANCE VOLUMETRIC PUMP
Pressure stability also with prolonged and contemporary use of more than one group.

COMPETITION FILTERS
Exclusive Sanremo design, with shape and volume designed to capture the best coffee aromas and fragrances.

TEMPCONTROL
For a very-high thermal stability (± 0.2 °C).

GROUP FLUSHING
With a simple pressure of the button a small quantity of water is dispensed to allow the group to be always clean.

Optional

AUTOSTEAMER
Steam wand characterized by an electronic system that allows to mount and/or heat milk at the set temperature.

EXTERNAL VOLUMETRIC PUMP

HIGH POWER STEAMER TERMINAL
(bigger holes diameter)

NAKED PORTAFILTERS

ENHANCED RESISTANCE

Verona

52

124 C° 10:00
SANREMO

TIME AND TEMPERATURE DISPLAY

only mod. SED



SED VERSION

Guarantees an electronic dosing system through the button panel



SAP VERSION

Allows the semi-automatic programming of doses



Verona
Link to the website

GROUP SR 61

Optimized to maintain the ideal coffee extraction temperature



Characteristics



ELECTRONIC AUTO-LEVEL
Through an electronic level probe the boiler is automatically filled and maintained to the right filling level.



ACTIVATED ELECTRONIC PRE-INFUSION
Management of the delayed activation of water solenoid in the first phase of brewing.



EASY SERVICE
Fast access to the internal parts for quick and easy technical service.

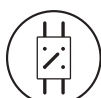

STATIC RELAY BOILER TEMPERATURE
Allows to regulate the temperature as accurately as possible.



MULTIFUNCTION DISPLAY
Allows to monitor the right functioning of the machine and to program the main functions.



AUTOMATIC CLEANING CYCLE
Process for coffee groups cleaning.









DOUBLE READING GAUGE
Allows to control at the same time the boiler pressure and the distribution pressure.



GROUP SR 61
Chromed brass grouphead with thermosiphonic circulation system optimized to maintain the ideal coffee extraction temperature.

Colours

	Red	RAL 3002
	Matte black	RAL 9005
	Black	RAL 9005
	Silver	RAL 9006
	Pearl white	RAL 1013
	White	RAL 9003



Versions

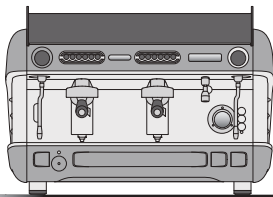

32' 2/4" / 820 mm

2 group SED/SAP

- 2 steam taps
- 1 water tap
- 1 one-cup filter holder
- 2 two-cup filter holders

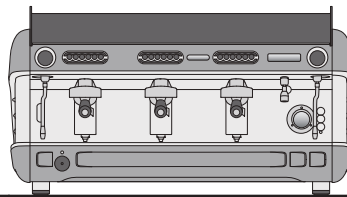

41' 2/4" / 1050 mm

3 group SED/SAP

- 2 steam taps
- 1 water tap
- 1 one-cup filter holder
- 3 two-cup filter holders

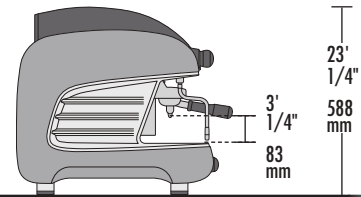

18' / 459 mm
23' 1/2" / 599 mm

23' 1/4" / 588 mm

3' 1/4" / 83 mm

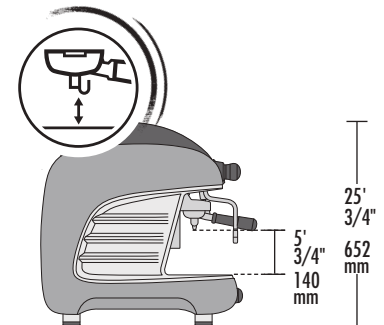

25' 3/4" / 652 mm

5' 3/4" / 140 mm

 **TALL VERSION**

Optional



AUTOSTEAMER

Steam wand characterized by an electronic system that allows to mount and/or heat milk at the set temperature.



COMPETITION FILTERS

Exclusive Sanremo design, with shape and volume designed to capture the best coffee aromas and fragrances.



EXTERNAL VOLUMETRIC PUMP



MIXED INFUSION HOT WATER FOR TEA AND HERBAL TEAS

Immediate mixing of cold / hot water for a better chemical and organoleptic quality.

Technical data

		2 group	3 group
voltage	V	220-240 1N / 380-415 3N	
max input boiler/steam boiler's resistor power	kW	3.3 / 2.7	5.35 / 5.1
		5.1 / 4.5	
steam boiler capacity	lt	12.7	19
pump power	kW	0.15	0.15
net weight	lb / kg	150 / 68	187 / 85
gross weight (with shipping crate)	lb / kg	161 / 73	201 / 91

*4 group machine available upon request



CUP WARMER

Dedicated resistor to keep all the cups at the optimal temperature.



NAKED PORTAFILTERS

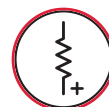

ENHANCED RESISTANCE

Napoli

54



LEVER GROUP
High-performance lever group with Sanremo technology

TEMPERATURE SETTING DISPLAY

Allows the regulation of the water temperature



Characteristics



MANUAL BOILER LOAD
Allows to bypass the electronic-level control.



ELECTRONIC AUTO-LEVEL
Through an electronic level probe the boiler is automatically filled and maintained to the right filling level.

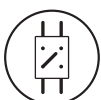

STATIC RELAY BOILER TEMPERATURE
Allows to regulate the temperature as accurately as possible.



GLASS LEVEL
Allows to monitor the water level in the boiler.



BOILER PRESSURE GAUGE
Allows to control the boiler pressure.



PUMP PRESSURE GAUGE
Allows to control the distribution pressure.



EASY SERVICE
Fast access to the internal parts for quick and easy technical service.



TEMPERATURE SETTING DISPLAY
Allows to regulate with precision the water temperature in the boiler for the production of coffee.

Optional



EXTERNAL VOLUMETRIC PUMP



ENHANCED RESISTANCE



CUP WARMER
Dedicated resistor to keep all the cups at the optimal temperature.



Versions

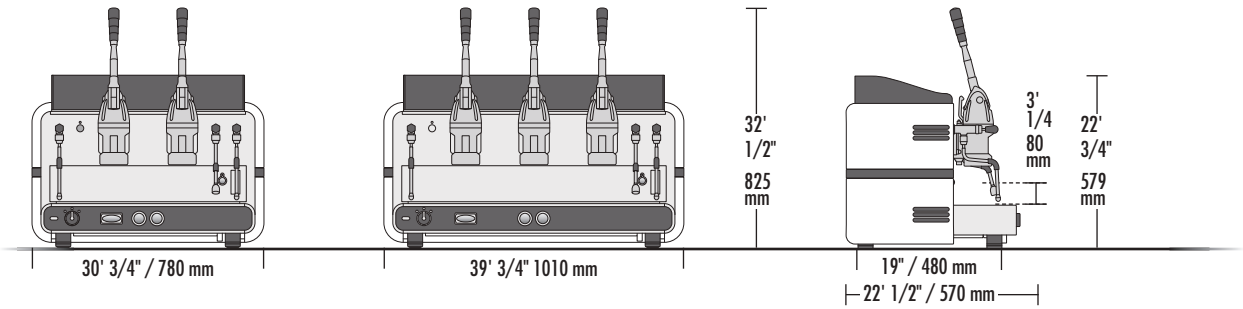

- 2 group**
- 2 steam taps
 - 1 water tap
 - 1 one-cup filter holder
 - 2 two-cup filter holders

- 3 group**
- 2 steam taps
 - 1 water tap
 - 1 one-cup filter holder
 - 3 two-cup filter holders



Colours

	Black	RAL 9005
	White	RAL 9003
	White Matte black	RAL 9003 9005
	White Red	RAL 9003 3002



Technical data		2 group	3 group
voltage	V	220-240 1N	380-415 3N
max input boiler/steam boiler's resistor power	kW	3.85 / 3.5	5.80 / 5.5
		4.85 / 4.5	7.40 / 7.0
steam boiler capacity	lt	12	19
pump power	kW	0.13	0.13
net weight	lb / kg	172 / 78	240 / 109
gross weight (with shipping crate)	lb / kg	194 / 88	254 / 115

*4 group machine available upon request



Napoli
Link to the website

Torino

56

LED LIGHTING OF THE WORKING AREA

Allows to effectively work in any light condition (optional)



SED VERSION

Guarantees an electronic dosing system through the button panel



SAP VERSION

Allows the semi-automatic programming of doses



GROUP SR 61

Optimized to maintain the ideal coffee extraction temperature



Characteristics



Torino
Link to the website



ELECTRONIC AUTO-LEVEL

Through an electronic level probe the boiler is automatically filled and maintained to the right filling level.



PUMP PRESSURE GAUGE

Allows to control the distribution pressure.



EASY SERVICE

Fast access to the internal parts for quick and easy technical service.



ACTIVATED ELECTRONIC PRE-INFUSION

Management of the delayed activation of water solenoid in the first phase of brewing.



GROUP SR 61

Chromed brass grouphead with thermosiphonic circulation system optimized to maintain the ideal coffee extraction temperature.



AUTOMATIC CLEANING CYCLE

Process to clean the coffee groups.



BOILER PRESSURE GAUGE

Allows to control the boiler pressure.



Versions

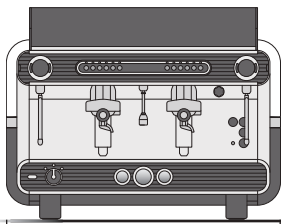

31" / 780 mm

2 group SED/SAP

- 2 steam taps
- 1 water tap
- 1 one-cup filter holder
- 2 two-cup filter holders

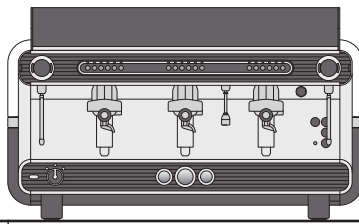

40" / 1010 mm

3 group SED/SAP

- 2 steam taps
- 1 water tap
- 1 one-cup filter holder
- 3 two-cup filter holders

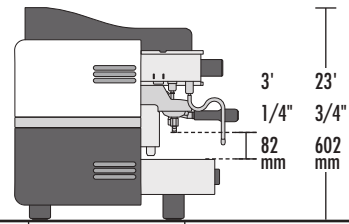

17' 1/3" / 440 mm
22' 1/2" / 570 mm

3" 23"
1/4" 3/4"
82 mm 602 mm

Colours

	Black	RAL 9005
	White	RAL 9003
	White Matte black	RAL 9003 9005
	White Red	RAL 9003 3002



Optional



LED LIGHTING OF THE WORK AREA
Allows efficient working in any condition of environmental lighting.



EXTERNAL VOLUMETRIC PUMP



CUP WARMER
Dedicated resistor to keep all the cups at the optimal temperature.



NAKED PORTAFILTERS



COMPETITION FILTERS
Exclusive Sanremo design, with shape and volume designed to capture the best coffee aromas and fragrances.



ENHANCED RESISTANCE



Technical data

		2 group	3 group
voltage	V	220-240 1N	380-415 3N
max input boiler/steam boiler's resistor power	kW	3.35 / 2.7	5.35 / 5.1
		5.1 / 4.5	
steam boiler capacity	lt	12	19
pump power	kW	0.15	0.15
net weight	lb / kg	139 / 63	196 / 89
		gross weight (with shipping crate)	lb / kg

Zoe Competition

58

COLORED AND VERSATILE

Totally matching every type of decorative solution thanks to the possible customizations



00

SHOT TIMER

To accurately and reliably time coffee extraction

LED LIGHTING OF THE WORKING AREA

Allows to effectively work in any light condition



EASY SERVICE

Fast access to the internal parts for quick and easy technical service



LOW SERVICE COST

Designed to decrease the maintenance and inspection costs



Characteristics



ELECTRONIC AUTO-LEVEL

Through an electronic level probe the boiler is automatically filled and maintained to the right filling level.



ACTIVATED ELECTRONIC PRE-INFUSION

Management of the delayed activation of water solenoid in the first phase of brewing.



DOUBLE READING GAUGE

Allows to control at the same time the boiler pressure and the distribution pressure.



EASY SERVICE

Fast access to the internal parts for quick and easy technical service.



AUTOMATIC CLEANING CYCLE

Process for coffee groups cleaning.



LED LIGHTING OF THE WORK AREA

Allows efficient working in any condition of environmental lighting.



SHOT TIMER

To accurately and reliably time coffee extraction.

Optional



AUTOSTEAMER

Steam wand characterized by an electronic system that allows to mount and/or heat milk at the set temperature.



CUP WARMER

Dedicated resistor to keep all the cups at the optimal temperature.



EXTERNAL VOLUMETRIC PUMP



NAKED PORTAFILTERS



ENHANCED RESISTANCE



Versions

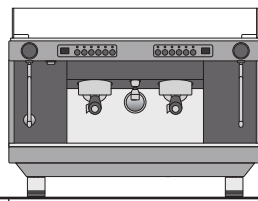

28' 2/4" / 720 mm

2 group

- 2 steam taps
- 1 water tap
- 1 one-cup filter holder
- 2 two-cup filter holders

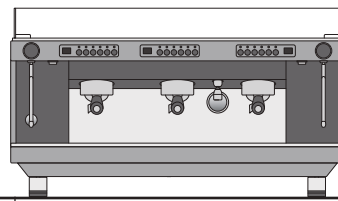

37' 2/4" / 950 mm

3 group

- 2 steam taps
- 1 water tap
- 1 one-cup filter holder
- 3 two-cup filter holders

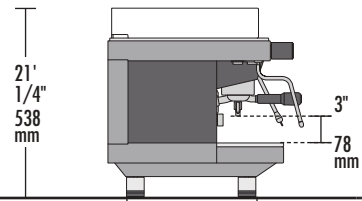

14' 1/2" / 368 mm
19' 2/3" / 500 mm

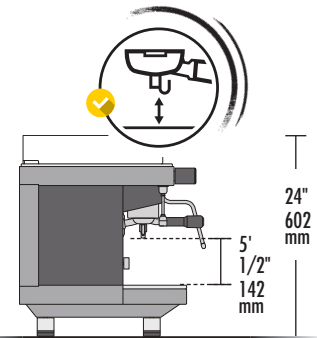

TALL VERSION

2-3 group



Technical data		2 group	3 group
voltage	V	220-240 1N	380-415 3N
max input boiler/steam boiler's resistor power	kW	3.35 / 2.7	5.8 / 5.1
		4.3 / 4.0	
		4.8 / 4.5	
steam boiler capacity	lt	9	12.5
pump power	kW	0.15	0.15
net weight	lb / kg	121 / 55	152 / 69
gross weight (with shipping crate)	lb / kg	130 / 59	161 / 73

Colours

	Black	RAL 9005
	White Black	RAL 9003 9005
	White Matte black	RAL 9003 9005
	White Red	RAL 9003 3002

PERSONALISED GRAPHICS

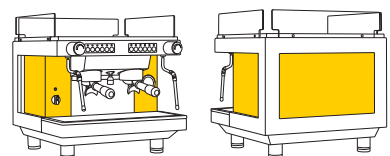

Customization of internal panels with graphics and colors (on request).



Zoe Competition
Link to the website

Zoe

60

COLORED AND VERSATILE

Totally matching every type of decorative solution thanks to the possible customizations



SED VERSION

Guarantees an electronic dosing system through the button panel



SAP VERSION

Allows the semi-automatic programming of doses



COMPACT



TALL



COMPLETE RANGE

Available versions: SED and SAP, 1-2-3 group, Tall and Compact



EASY SERVICE

Fast access to the internal parts for quick and easy technical service



LOW SERVICE COST

Designed to decrease the maintenance and inspection costs



Characteristics



ELECTRONIC AUTO-LEVEL

Through an electronic level probe the boiler is automatically filled and maintained to the right filling level.



ACTIVATED ELECTRONIC PRE-INFUSION

Management of the delayed activation of water solenoid in the first phase of brewing.



DOUBLE READING GAUGE

Allows to control at the same time the boiler pressure and the distribution pressure.



EASY SERVICE

Fast access to the internal parts for quick and easy technical service.



AUTOMATIC CLEANING CYCLE

Process for coffee groups cleaning.

Optional



AUTOSTEAMER

Steam wand characterized by an electronic system that allows to mount and/or heat milk at the set temperature.



CUP WARMER

Dedicated resistor to keep all the cups at the optimal temperature.



EXTERNAL VOLUMETRIC PUMP



NAKED PORTAFILTERS



ENHANCED RESISTANCE



Versions

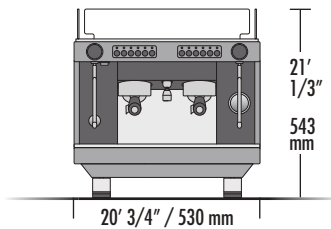
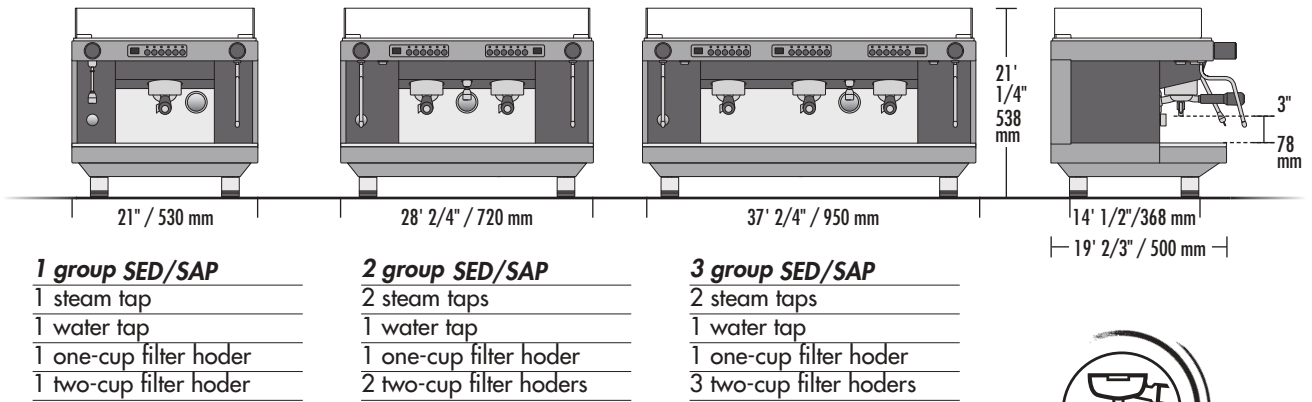

COMPACT VERSION

- 2 group**
 2 steam taps
 1 water tap
 1 one-cup filter holder
 2 two-cup filter holders

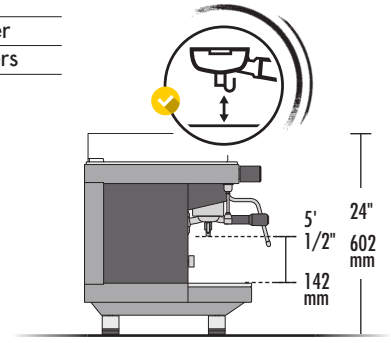

TALL VERSION

- 2-3 group**
SED
SAP

Technical data		1 group	2 group	3 group	Compact
voltage	V	220-240 1N / 380-415 3N			220-240 1N
max input boiler/steam boiler's resistor power	kW	2.35 / 1.95	3.35 / 2.7	5.8 / 5.1	2.7 / 2.5
			4.3 / 4.0		
			4.8 / 4.5		
steam boiler capacity	lt	5	9	12.5	7
pump power	kW	0.15	0.15	0.15	0.15
net weight	lb / kg	93 / 42	121 / 55	152 / 69	99 / 45
gross weight (with shipping crate)	lb / kg	104 / 47	130 / 59	161 / 73	113 / 51

Colours

	Black	RAL 9005
	White Black	RAL 9003 9005
	White Matte black	RAL 9003 9005
	White Red	RAL 9003 3002

PERSONALISED GRAPHICS

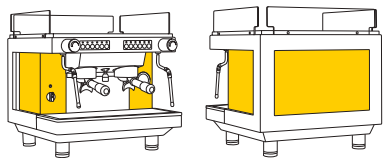

Zoe
 Link to the website

Customization of internal panels with graphics and colors (on request).

Cube

62



STAINLESS STEEL "COLD TOUCH"

Anti-burning feature fitted with "Latte Art" high-performance steam terminals

STEAMBOOSTER

Increase the power of the steam wand, improving performance



MAIN DISPLAY

Views:

- Boiler temperature (range 239/ 258,8°F)
- Extraction time
- Water level
- Malfunction

Settings:

- Water filter expiration date (1-12 mths)

APP CONNECTION



LED INDICATORS

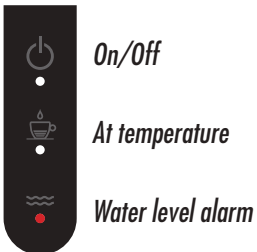

ENERGY SAVING SYSTEM

Component insulation and smart electronics for maximum energy efficiency



PRESSURE GAUGE BOILER PRESSURE

Range 0–36 psi



PRESSURE GAUGE PUMP PRESSURE

Range 0–232 psi



Characteristics

1.9L BOILER IN AISI 316 STAINLESS STEEL

1.8L INTERNAL WATER TANK

WATER SUPPLY THAT CAN BE SELECTED FROM INTERNAL TANK OR MAINS

THERMOSYPHON UNIT WITH MECHANICAL PRE-INFUSION

BOILER POWER 1300W/120VAC

54 L/H HIGH PERFORMANCE VOLUMETRIC PUMP

ENERGY SAVING SYSTEM SELECTABLE AND PROGRAMMABLE

WIFI CONNECTION WITH WEB APP

DIGITAL DISPLAY

Optional

NAKED PORTAFILTERS

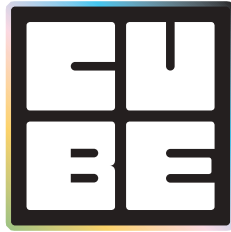

Versions

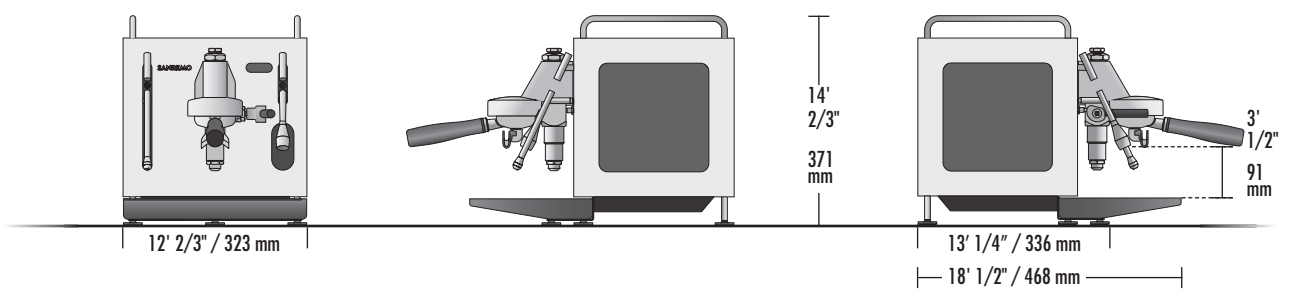

WeightKg 27,7 | 61 lbs



Cube
Link to the website

WiFi connection with Web App



It is possible to manage multiple machines - located in different places - using the same App.







- + Remote machine on/off
- + Set-up boiler temperature
- + Manage water tank level
- + Enable and manage water filter signaling
- + Show shot time in real time
- + Statistics: daily, weekly and monthly counters for coffee and water consumption
- + Weekly scheduler to program up to three different "time slot" per day

APP & WI-FI TECHNOLOGY



CUBE



-  Snow White
-  Onyx Black
-  Stainless Steel
-  Azure Lake
-  Candy Pink
-  Matcha Green
-  Yolk Yellow
-  Racing Red



2 different body styles: A and B.

_ Cube A

In style A, the machine coating panels come in single colour.



Standard colours



Special colours



65

_ Cube B

In style B, the side panels feature two parts characterised by a two-colour finish.



Available finishes of the body



Available finishes for the central box



Cube Kit

Kit Wood



Kit includes two magnetic panels with wood finish.

66

Available finishes of the body



Wood panels finishes

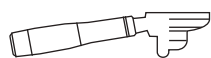
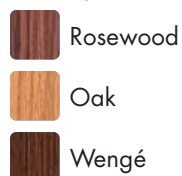

Filter holder



Knob

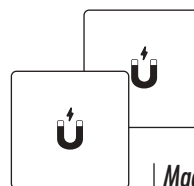

Magnetic panels

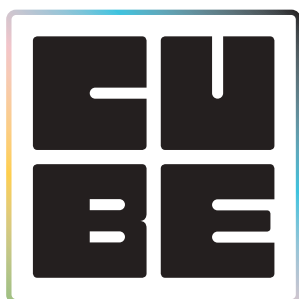

Kit Accessories



+



Light wood

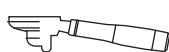

+

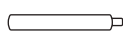

Dark wood

Kit includes 1 filter holder and 1 knob with a wood finish chosen from the following.

Choose the CUBE kit of your choice!

Kit Leather



Kit includes two magnetic panels with branded leather finish.

Available finishes of the body



Wood panels finishes

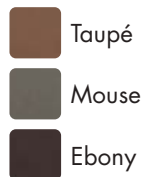

Kit Extra



Kit includes two magnetic panels with studded leather finish.

Available finishes of the body

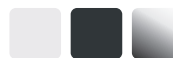

Extra panels finishes

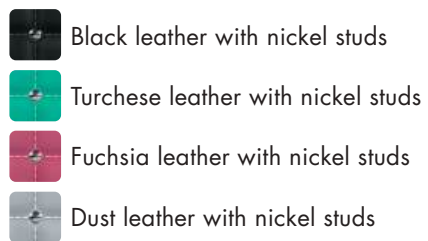

You

68



CUSTOMIZABLE PRESETS



USER-FRIENDLY

Intuitive touch screen display

FRONT LEVER (PADDLE)

Electronically managed to create and modify profiles



ENERGY SAVING SYSTEM

Component insulation and smart electronics for maximum energy efficiency

MULTI-BOILER

The boilers for both the coffee and the auxiliary services are made from AISI 316 stainless steel, and are fully insulated

FULL CONFIGURATION

Equipped with tank (2,5 l) and water mains connection



CONNECTIVITY

USB and Wi-Fi



VOLUMETRIC PUMP

*24V 70 litres
Excellent stability during profiling*

Characteristics



MIXED INFUSION HOT WATER FOR TEA AND HERBAL TEAS

Immediate mixing of cold / hot water for a better chemical and organoleptic quality.



STATIC RELAY BOILER TEMPERATURE

Allows to regulate the temperature as accurately as possible.



STAINLESS STEEL COFFEE BOILER

Guarantees excellent stability and thermal precision, associated with resistance to oxidation and limestone.



LED LIGHTING OF THE WORK AREA

Allows efficient working in any condition of environmental lighting.



AUTO-ON, AUTO-OFF AND DAY-OFF FUNCTION

Programmable ON-OFF/ON-ECO timer for each day and/or daily timetables.



EASY SERVICE

Fast access to the internal parts for quick and easy technical service.



AUTOMATIC CLEANING CYCLE

Process for coffee group cleaning.



ENERGY SAVING SYSTEM

Component insulation and smart electronics for maximum energy efficiency.



TEMPCONTROL

For a very-high thermal stability (± 0.2 °C).



GROUP FLUSHING

With a simple pressure of the button a small quantity of water is dispensed to allow the group to be always clean.



VOLUMETRIC PUMP

A new generation of pump to amplifying your experience



Versions

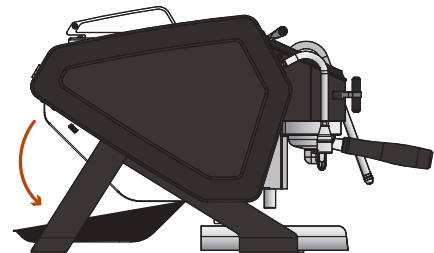
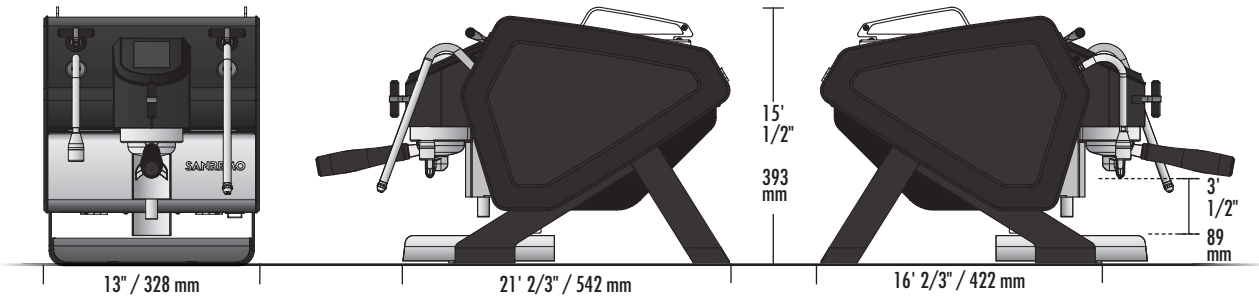

Technical data		
voltage/max input boiler	V	220-240V / 50-60HZ / 2.20 kW
		110-120V / 50-60HZ / 1.65 kW
		100V / 50-60HZ / 1.45 kW
coffee boiler's resistor power	W	500
steam boiler capacity	lt	1
coffee boiler capacity	l	0.5
net weight	lb / kg	70.5 / 32
gross weight	lb / kg	79 / 36

Colours

	Black: matt glossy (side frames)	RAL 9005
	White: matt glossy	RAL 9003
	Black: legs and side	RAL 9005
	White: matt glossy (side frames)	RAL 9003

Customizations available, see YOU_KIT catalogue for more info

Optional



NAKED PORTAFILTERS



You
Watch the video

Customizable Presets

Extraction profiles customizable and savable:

- 6 standard profiles with optimal parameters presets.
- 12 completely customizable profiles in all 3 extraction phases, with a capacity to disable pre-infusion and post-infusion the Paddle.
- Set your manual profiles from the Paddle.



70

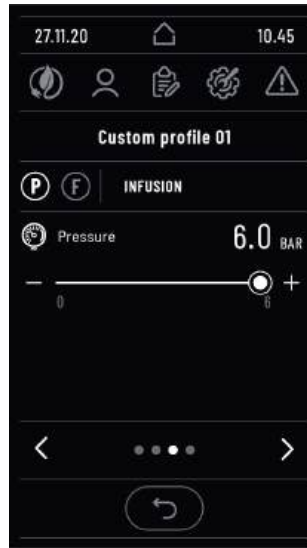

Extraction mode

Check your extraction in **real time** verifying pressure **flow rate**.

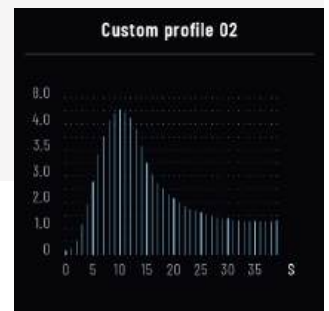
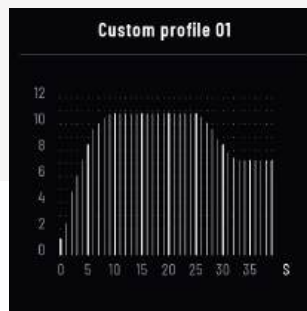
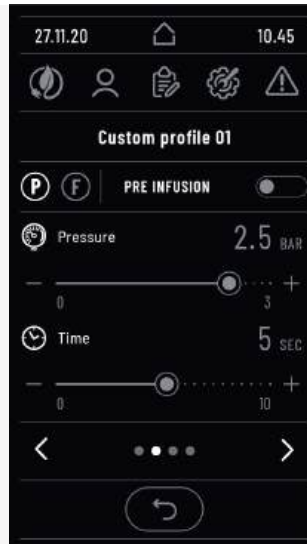
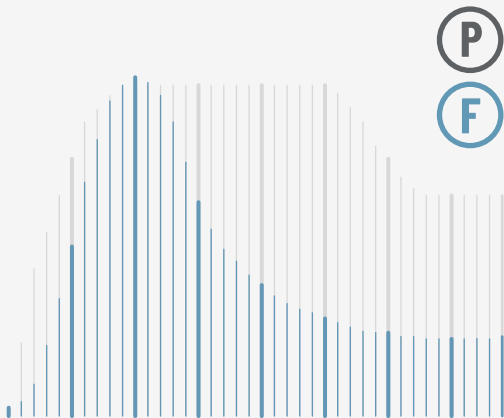

Electronic Paddle

Manually create your profiles.

Configure the Paddle (right/left) based on your gestures.



YOU
MADE FOR YOU BY SAHREMO



Energy efficiency

Setting:

- **Automatic:** allows the user to associate up to 6 daily time frames.
- **Manual:** allows the user to turn the machine or the individual boilers on and off manually.

Two programmable modes:

- **Stand-by:** low power consumption condition, compliant with the ErP Directive (2009/125/EC).
- **Eco:** keeps the machine on, but at a reduced temperature for quick start-up.

For both, the user can enable the Energy Saving function, which automatically turns the machine off after the set time.

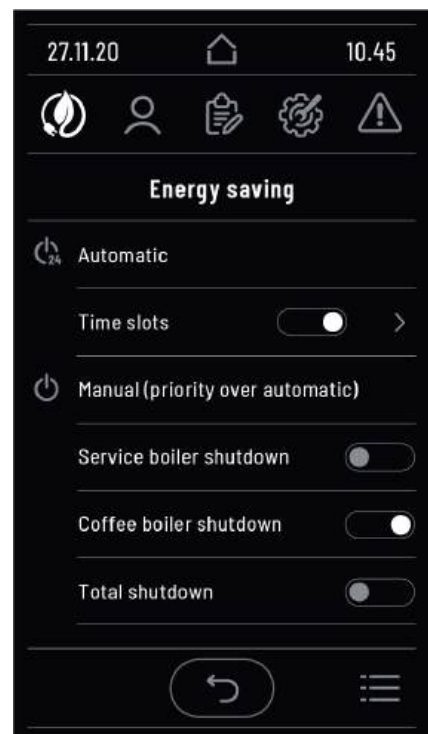

You Kit

Wood





Kit includes two magnetic panels with wood finish.

72



Wood panels finishes

-  Rosewood
-  Oak
-  Wengé



Kit Accessori

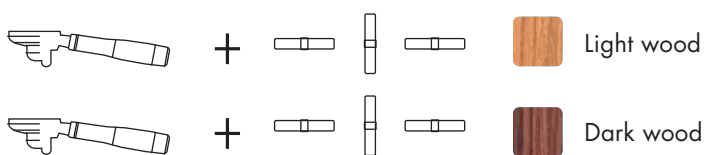

Kit includes 1 filter holder and 3 knobs with a wood finish chosen from the following.

You is available in three different coverings to customize



Total white



Total Black



Black & White

Leather

Kit includes two magnetic panels with leather finish.



Leather panels finishes



Mouse



Taupé



Ebony

73



Extra

Kit includes two magnetic panels with studded leather finish.



Extra panels finishes



Black leather with copper studs

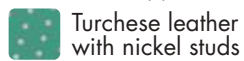

Turquoise leather with nickel studs

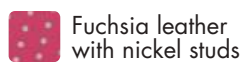

Fuchsia leather with nickel studs

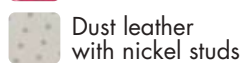

Dust leather with nickel studs





Aquamarine

TOTAL WHITE

Copper Gold



SELECT
YOUR
MODEL



Champagne

Champagne



**SPECIAL
EDITION**

75

Aquamarine



Copper Gold



TOTAL BLACK



Grinders



GRINDERS
SAHREMO

X-ONE

78



HIGH PERFORMANCE

Vertical flat burrs (ø 98 mm)
Burrs with DLC coating

INTEGRATED INDUSTRIAL GRADE WEIGHING

Only the requested dose is grinded
Patented "WEIGHT BY BEANS" technology to weigh beans before grinding



EVERYTHING UNDER CONTROL

Display full touch screen

GRINDING SPEED

3 standard speeds:
1000 rpm | 1200 rpm | 1400 rpm
1 custom speed: range 800 – 1400 rpm
Selectable by user on digital display

3 GRINDERS IN 1

BY-PASS

Can be used as single dose or up to 250 g

GRINDING CHAMBER

Always empty.
No coffee is wasted



PRESET RECIPES

You can save up to 12 customized recipes - you can set weight, grinding speed and burrs distance. Save & upload on USB

GRINDING MOTOR

Managed by an inverter to control grinding speed



Characteristics



EMPTY CHAMBER
No more coffee is wasted and no more oxidation avoiding rancid flavours.



VERTICAL FLAT BURRS
98 mm vertical flat burrs with DLC coating to reduce friction of coffee and increase life span.



EASY SETTING
Electronic burrs' spacing adjustment.



INDUSTRIAL WEIGHING SYSTEM
Industrial weighing system, for 5 to 30 g for each hopper.



PREDOSING FEATURE
Automatically refill your dose to improve the productivity.



HOPPERS
Two independent hoppers for different coffees and recipes.



BYPASS
Useful for single dose or up to 250 g; independent with its own setting.



FLEXIBILITY
Manual dosing pushbutton for each hopper.



SPACE FOR COFFEE BAG
Easy removable portafilter holder.



HEALTH
Hoppers and bypass use material "PBA-Free".



COOLING SYSTEM
Temperature controlled cooling system.



Benefits of single dose

Volatile compounds in roasted and ground coffee.
Effect of time in coffee aroma intensity.

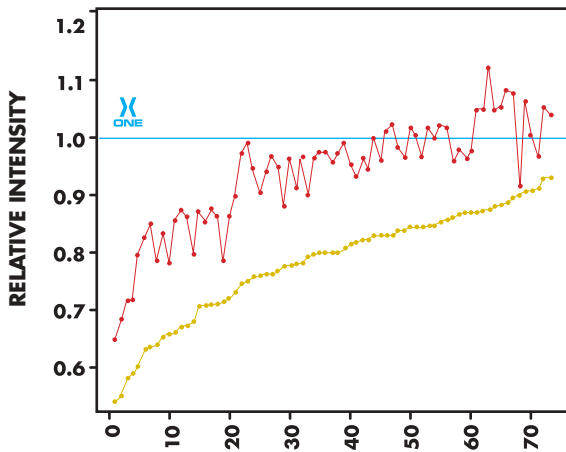

Molecular mass (m/z)
Each dot is a different chemical compound found inside coffee.

AROMA INTENSITY CHART

- X-ONE Single dose grinding reference intensity line
- On-demand Coffee compound intensity 1min after grinding
- On-demand Coffee compound intensity 20min after grinding

RESULT

HIGHEST AROMA CONTENT IN SINGLE DOSING (X-ONE).

SIGNIFICANT DECREASE OF AROMA CONTENT WHEN COFFEE IS WAITING IN THE ON-DEMAND GRINDER FOR NEXT DOSE AS RETENTION BUILDS.

Technical data		X-ONE
Version 1	W	100-127Vac / 50-60Hz / 1550W
Version 2	W	200-240Vac / 50-60Hz / 1650W
burrs' type	-	3.85"/98 mm vertical flat
motor speed	rpm	800 -1400
coffee beans hopper capacity	lb / kg	2x2.6 / 2x1.2
by-pass capacity	lb / gr	0.55 / 250
net weight	lb / kg	79 / 36
width	inch / mm	9" / 230
height	inch / mm	23" / 580
dept	inch / mm	20" / 510

X SPACE SAVING

Footprint impact of three standard grinders.

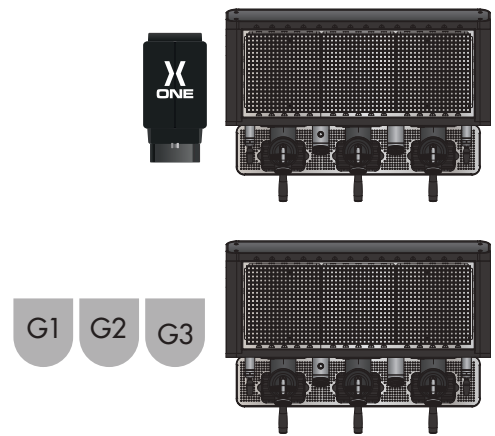

Colours



To find out more about the Sanremo X-One



On demand / Grinder doser

SR 83 OD



80



HIGHT PERFORMANCE

Flat burrs (ø 83 mm)
"Dark-T" burrs (optional)

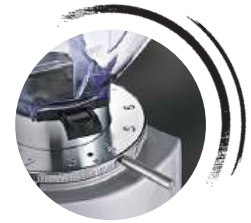

PRECISE GRINDING ADJUSTMENT

Mechanical micrometric with ring nut

EVERYTHING UNDER CONTROL

Display full touch screen

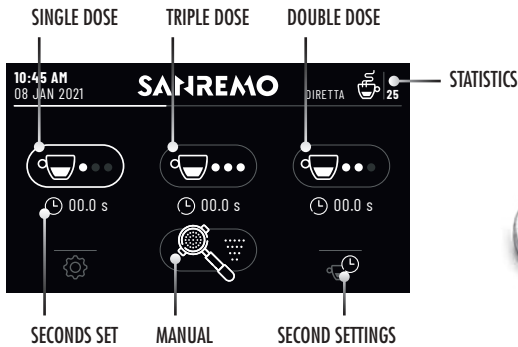

CE

Optional



"DARK-T" BURRS

Improves the quality of grinding and offers a much longer life span. (PVD-coated)



INVERTER TECHNOLOGY

The system ensures absolute precision and consistency for grinding, reducing motor consumption, operating noiselessly and showing exceptional reliability even during long time operations.

Technical data

		SR 83 OD
power	W	650
burrs	-	flat
disks diameter	inch / mm	3' 1/4" / 83
motor speed 50 Hz	rpm	1350
motor speed 60 Hz	rpm	1550
coffee beans hopper capacity	lb / kg	3.3 / 1.5
net weight	lb / kg	33 / 15
width	inch / mm	9" / 230
height	inch / mm	26' 2/4" / 670
dept	inch / mm	10' 3/4" / 270

On demand / Conical grinder doser

SR 64 OD



HIGHT PERFORMANCE
 Flat burrs (ø 83 mm)
 "Dark-T" burrs (optional)

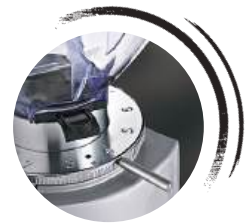

PRECISE GRINDING ADJUSTMENT
 Mechanical micrometric with ring nut

EVERYTHING UNDER CONTROL
 Display full touch screen

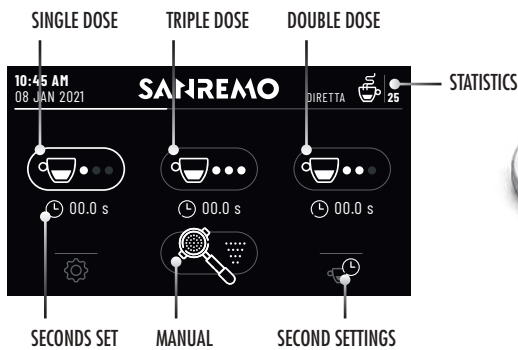

Grinders
 Link to the website



Colours	
	Matt White
	Pearl White
	Gloss Red
	Silver
	Nardo Gray
	Matt Black
	Gloss Black

• Shiny aluminium version available on request, with a price increase

Technical data		SR 64 OD
power	W	350
burrs	-	flat
disks diameter	inch / mm	2' 2/4" / 64
motor speed 50 Hz	rpm	1350
motor speed 60 Hz	rpm	1550
coffee beans hopper capacity	lb / kg	3.3 / 1.5
net weight	lb / kg	28.6 / 13
width	inch / mm	9" / 230
height	inch / mm	24' 1/4" / 615
dept	inch / mm	10' 3/4" / 270

On demand / Grinder doser

ON DEMAND



SR 83 OD PRO

82



HIGHT PERFORMANCE

Flat burrs (ø 83 mm)
"Dark-T" burrs (optional)



PRECISE GRINDING ADJUSTMENT

Mechanical micrometric with ring nut

EVERYTHING UNDER CONTROL

Display full touch screen



DETACHABLE GRINDING CHAMBER

Easy to release

Available for
SR 83 OD PRO and
SR 64 OD EVO PRO



CE

Optional



"DARK-T" BURRS

Improves the quality of grinding and offers a much longer life span. (PVD-coated)

Available for SR 83 OD, SR 64 OD EVO and SR 64 OD EVO PRO models.

Technical data		SR 83 OD PRO
power	W	650
burrs	-	flat
disks diameter	inch / mm	3' 1/4" / 83
motor speed 50 Hz	rpm	1350
motor speed 60 Hz	rpm	1550
coffee beans hopper capacity	lb / kg	3.3 / 1.5
net weight	lb / kg	33 / 15
width	inch / mm	9" / 230
height	inch / mm	26' 2/4" / 670
dept	inch / mm	10' 3/4" / 270

On demand / Grinder doser

ON DEMAND



SR 64 OD EVO PRO

SR 64 OD EVO



HIGHT PERFORMANCE

Flat burrs (ø 83 mm)
"Dark-T" burrs (optional)

EVERYTHING UNDER CONTROL

Display full touch screen

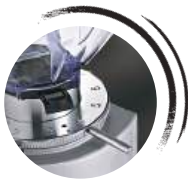

PRECISE GRINDING ADJUSTMENT

Mechanical micrometric with ring nut



DETACHABLE GRINDING CHAMBER

Easy to release

Available for
SR 83 OD PRO and
SR 64 OD EVO PRO



Colours	
	Matt White
	Pearl White
	Gloss Red
	Silver
	Nardo Gray
	Matt Black
	Gloss Black

• Shiny aluminium version available on request, with a price increase

Technical data		SR 64 OD EVO PRO	SR 64 OD EVO
power	W	350	350
burrs	-	flat	flat
burrs diameter	inch / mm	2' 2/4" / 64	2' 2/4" / 64
motor speed 50 Hz	rpm	1350	1350
motor speed 60 Hz	rpm	1550	1550
coffee beans hopper capacity	lb / kg	3.3 / 1.5	3.3 / 1.5
net weight	lb / kg	28.6 / 13	28.6 / 13
width	inch / mm	9" / 230	9" / 230
height	inch / mm	24' 1/4" / 615	24' 1/4" / 615
dept	inch / mm	10' 3/4" / 270	10' 3/4" / 270

AllGround

**CU
BE**

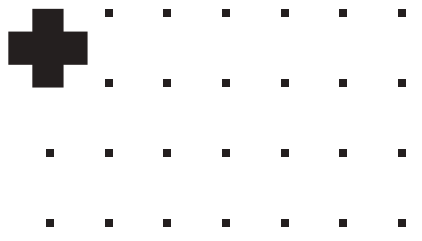
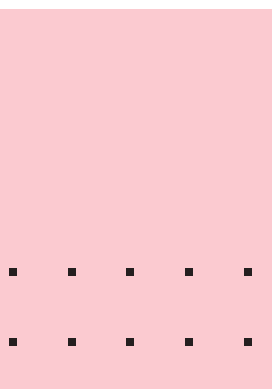

CUBE Grinders AllGround



Snow White



Onyx Black



Stainless Steel



Azure Lake



Candy Pink



Matcha Green



Yolk Yellow



Racing Red



CE

Technical data		
power	W	250
burrs	-	flat with titanium coating
burrs diameter	inch / mm	2' 2/4" / 64
motor speed 50 Hz	rpm	1400
motor speed 60 Hz	rpm	1600
coffee beans hopper capacity	lb / kg	0.55 / 0.25
net weight	lb / kg	19.8 / 9
width	inch / mm	6' 3/4" / 169
height	inch / mm	17' 1/4" / 440
dept	inch / mm	9' 2/4" / 240

made for
each other



