

Bågen monteras i
det främre hålet

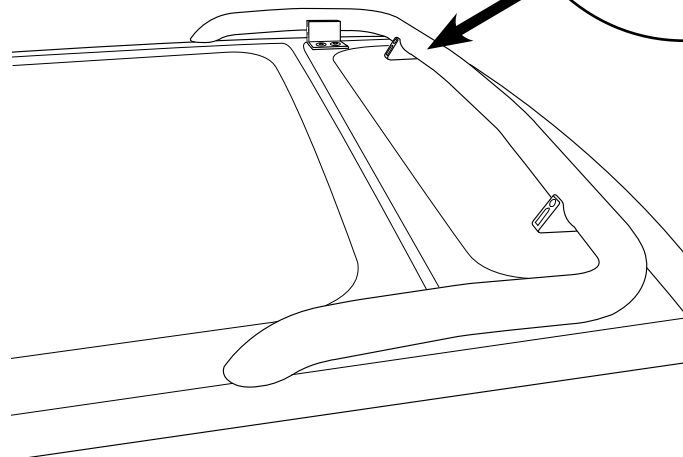

Nr	Ant	Ändring	Datum	Godk.
B		Svetsat fäste borttaget	2025-11-19	

A (1 : 2)

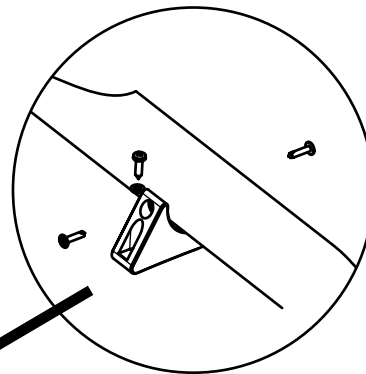
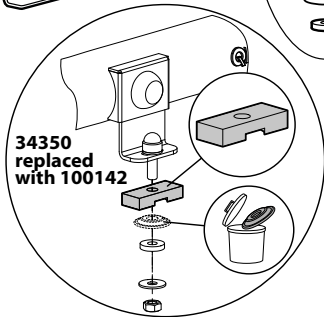
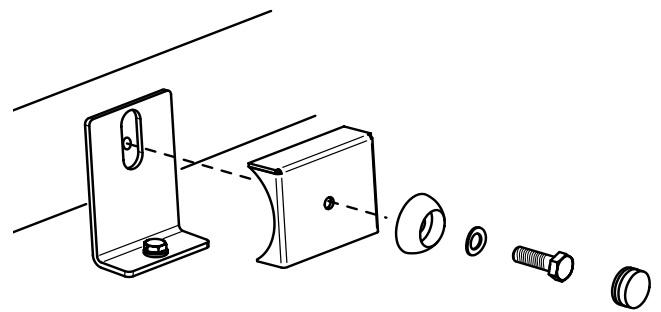
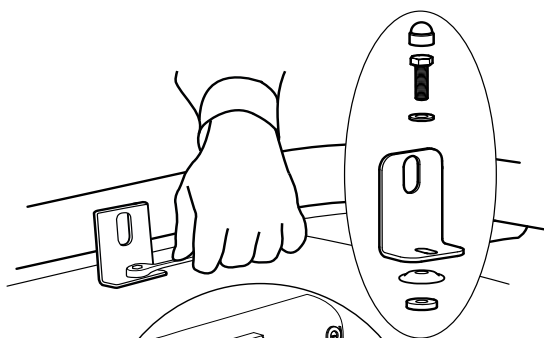
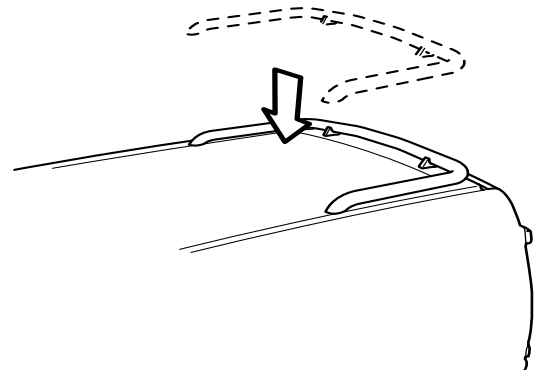
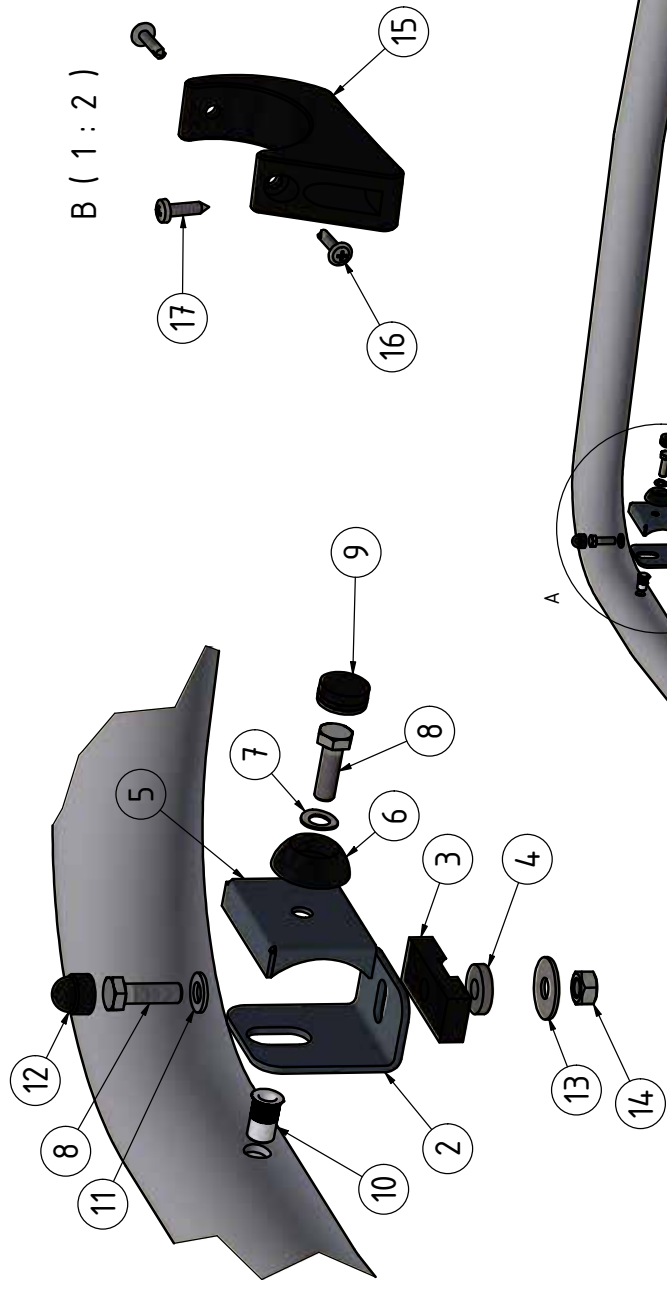

B (1 : 2)

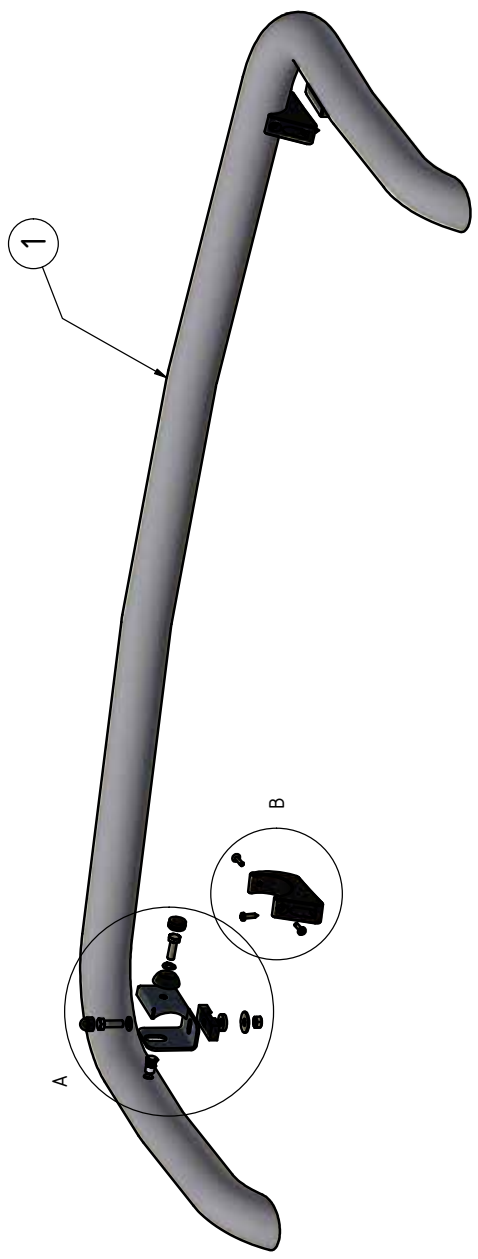

Pos	Ant	SMST Titel	Dimension	Artikel nr./Referens
17	2	Skruv RXS	4,2x19	34162
16	4	Montageskruv L19	4,2x19	34094
15	2	Magnetfäste	T=25	100141
14	2	Mutter M8 Locking	M8 Lås	34204
13	2	Bricka M8+	25x8x1,5	34315
12	2	Muterskydd 13mm	M8	50944
11	2	Bricka M8	8,4x16x1,5	34302
10	2	Nitmutter M8 Alu	M8 Ø11mm	32211
9	2	Hatt		50920
8	4	Skruv M6S	M8x25	34105
7	2	Bricka fjäder M8 rostfri	15x8,6x0,8	34329
6	2	Hattbricka	Ø32mm	50921
5	2	Täcklock	T=2	100209
4	2	Tätningbricka	20x8x4	50935
3	2	Mellanlägg Unifäste	50x10x20	100142
2	2	Vinkel 43mm 90° Plus	T=3	101205
1	1	T-RACK Takbåge	Ø60x3,5	B7-352
				Artikel nr./Referens

Konstr.	HW	Ritad	HW	Kop.		Kontr.	Stand.	Godk.	Skala	1 : 6	Ersätter	Ersatt av	
<p>Dar ej annat anges, gäller SS-ISO 2768 - C och SMS 723 - B. Svetskvalité för svetsar enligt SS - ISO 9817 m.m.C.</p>													
<p>QPAX T-RACK Takbåge Ford Transit Custom 13-</p>													
										Filnamn	93169.lidw	Datum	2025-11-19
										Art. nr	93169	Rev	B
<p>Tel: +46 (0)651-760460 Mail: info@qpx.se</p>													

Denna handling får inte kopieras utan vårt skriftliga medgivande och dess innehåll får inte yppas för tredje man och inte heller användas för något obehörigt ändamål.