



## Q-LED TOYOTA HILUX 21-

Art nr: QL90137  
Monteringsats: 93470



### Installation

Produkten monteras med Q-grip systemet.  
Infästning kläms runt krockbalken.



QPAX AB® Pellvägen 4, S-827 63 Färila  
Telefon: +46(0)651-760 460 | E-post: info@qpax.se | qpax.se

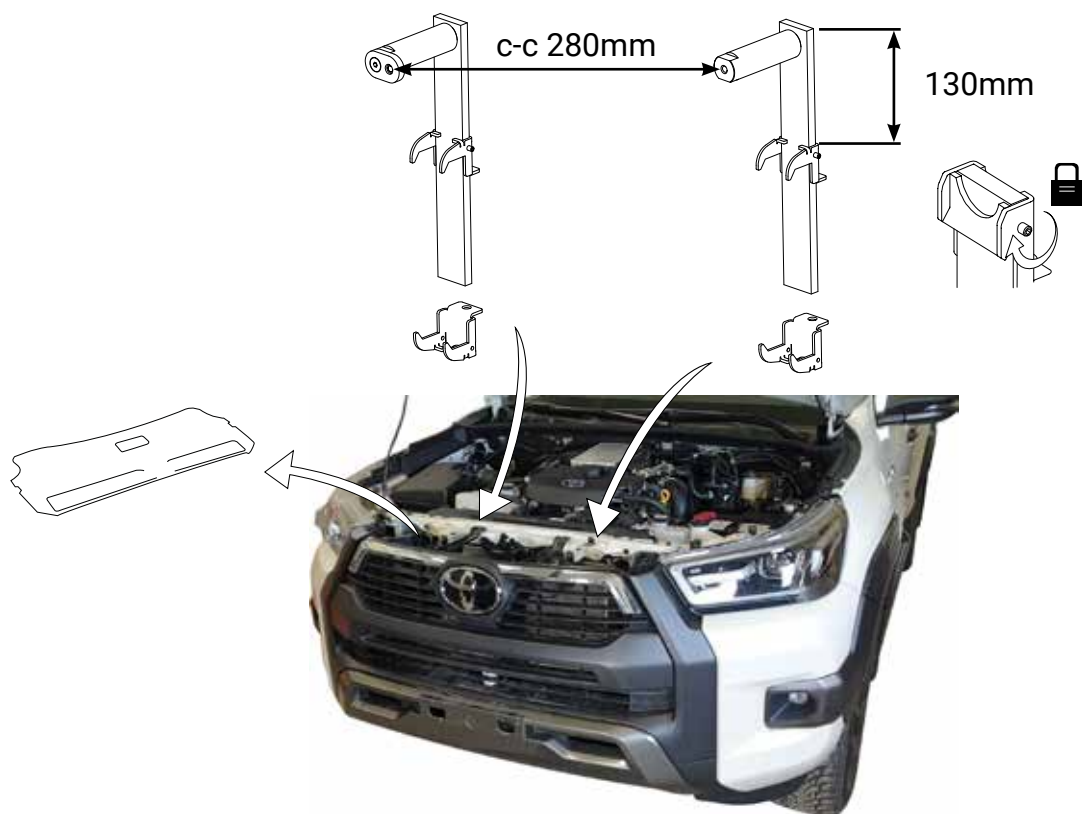

c-c 280mm



M8x90 (2x)



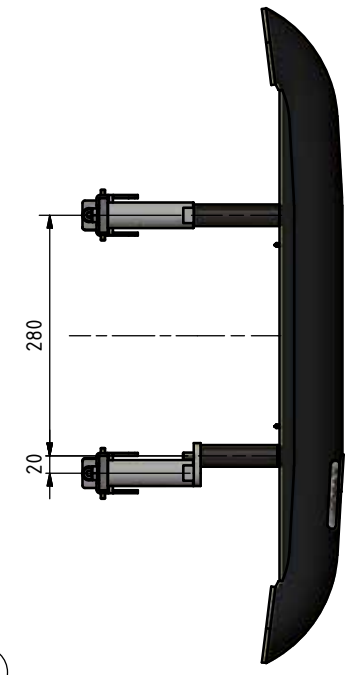
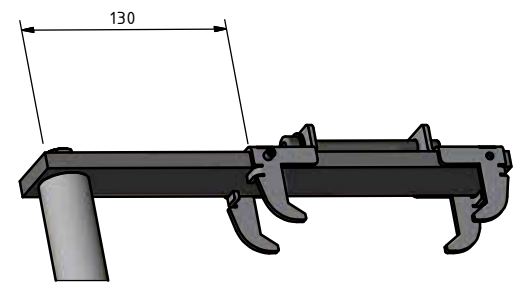

Pos	Ant	SMST	Titel	Dimension	Artikel nr/Referens
24	2		Täcklock	T=5	100624
23	1		Dekal Q-LED		60320
22	1		Dekal QPAX		60305
21	2		Montageskruv	4,2x14	34094
20	2		Plastdistans	15x6x6	50909
19	1		Q-LED	L10-152	
18	1		Reklamlist Qpax		98021
17	1		Skyllhållare		98020
16	2		Sexkantskruv	M8x120	34151
15	2		Bricka bred	8x22x1,5	34314
14	1		Skruv försänk	M8x20	34171
13	1		Distansbricka	Ø25x3	50957
12	1		Sänkbricka 20mm		100617
11	1		Aludistans	Ø25x100	10899
10	1		Aludistans Ø25x90	Ø25x90	10898
9	2		Sexkantskruv	M8x90	34173
8	2		Sexkantskruv	M10x30	34106
7	2		Bricka Nordlock	M10	34327
6	2		Bricka Nordlock Bred	M8	34328
5	4		Stoppsskruv	M5x8	34114
4	2		Q-GRIP Ståldistans Ø30x100	Ø30	100237
3	2		Q-GRIP Klo 25-30 gänga	T=3	100576
2	2		Q-GRIP Klo 25-30	T=3	100575
1	2		Q-grip plattjärn	40 x 10	100761
Pos	Ant		SMST	Titel	Artikel nr/Referens

Denna handling får inte kopieras utan vårt skriftliga medgivande och dess innehåll får inte yppas för tredje man och inte heller användas för något obehörigt ändamål.

Konstr.	Ritad	Kop.	Kontr.	Stand.	Godk.	Skala	Ersätter	Ersatt av
JNO	JNO					1 : 4		
Där ej annat anges, gäller SS-ISO 2768 - C och SMS 723 - B. Sveisväik för sveisar enligt SS - ISO 5817 nivå C.								
<p>QPAX Tel: +46 (0)65 1-700-640 Mail: info@qpax.se</p>						Filnamn 93470.idw		Datum 2021-03-05
						Art. nr 93470		Rev
								A