



Q-LED FORD TRANSIT 14-

Art nr: QL90047
Mounting kit: 93272



Installation

Mounted to the front frame in existing screw holes.



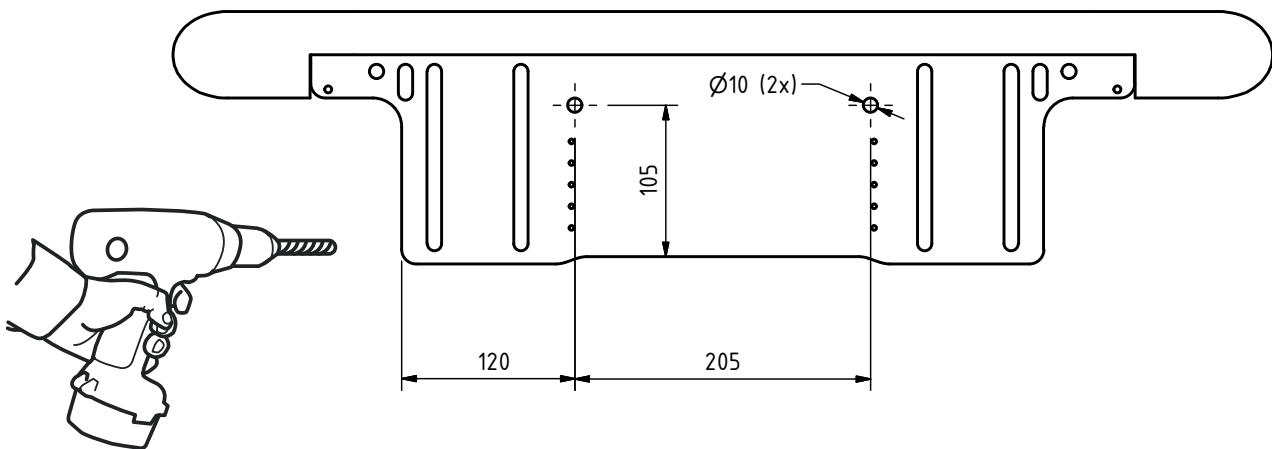
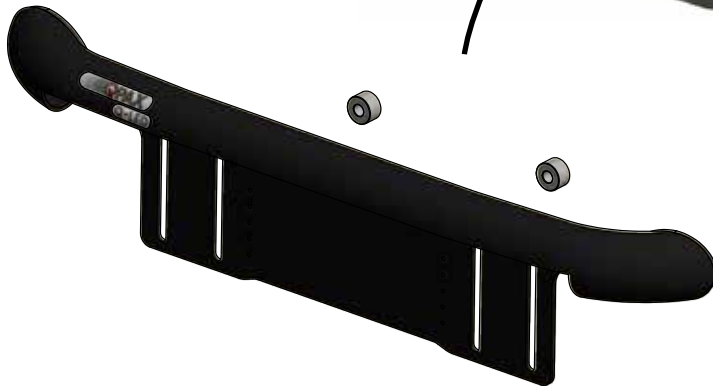
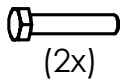

BORRMÅTT FÖR TRANSIT 14-

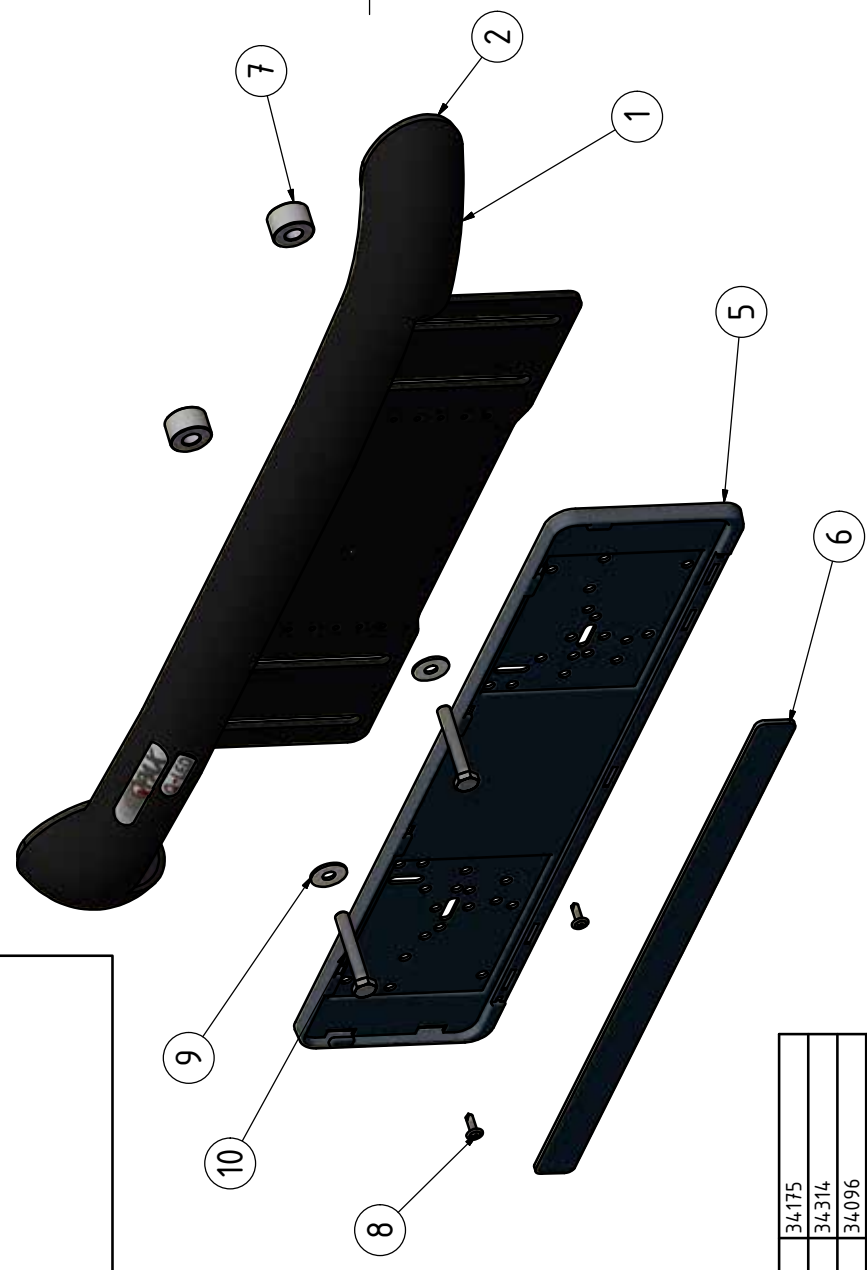
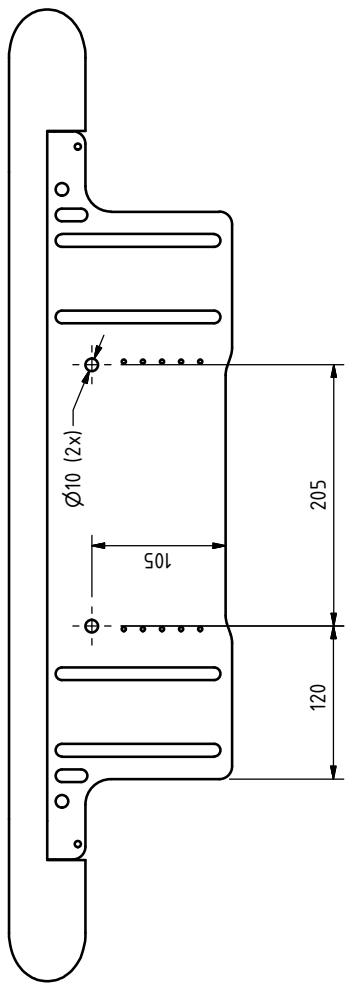

10	2	Sexkantsskruv	Stainless Steel, 440C	34175	
9	2	Bricka	Steel	34314	
8	2	Montage skruv PK typ M-II	Stainless Steel, 440C	34096	
7	2	Aludistans	ENAW 6082	50963	
6	1	Reklamlist Qpax	Polycarbonate	98021	
5	1	Skyllhållare	Polycarbonate	98020	
4	1	Dekal QPAX	Silicone	60305	
3	1	Dekal Q-LED	Domes	60320	
2	2	Täcklock	Rubber	100624	
1	1	LED Fäste	L10-152		
Pos	Ant	SMST Titel	Material	Dimension	Artikel nr/Referens

Konstr.	Ritad	Kop.	Kontr.	Stand.	Godk.	Skala	Ersätter	Ersatt av
JNO	JNO					1 : 3		
Dir ej annat anges, gäller SSISO 2768 - C och SMS 723 - B. Sverkeval för sveisar enligt SS - ISO 5817 nivå C.								
Q-LED Ford Transit 14-							Finamn	Datum
							93272.idw	2017-08-03
							Art. nr	Rev
							93272	A



Tel: +46 (0)61 766 460
email: info@qpax.se