



T-RACK

TRAFIC 15- / NV300 17- / VIVARO 15-19

Art nr: TF90037, TF90044 & TB90038
Monteringsatts: 93498



Installation

Produkten monteras i befintliga
infästningspunkter.



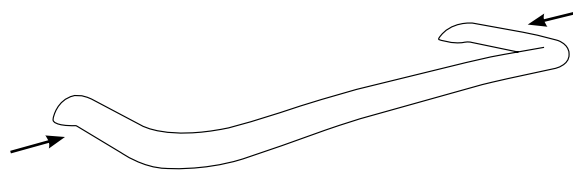
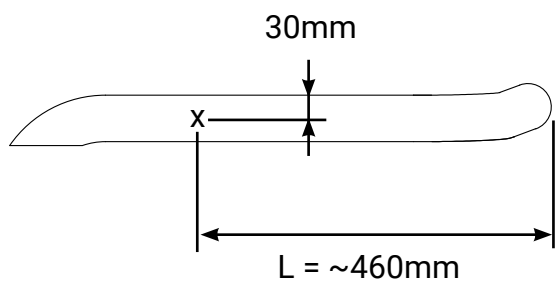

1.

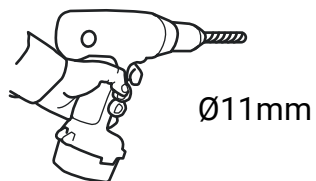

2.

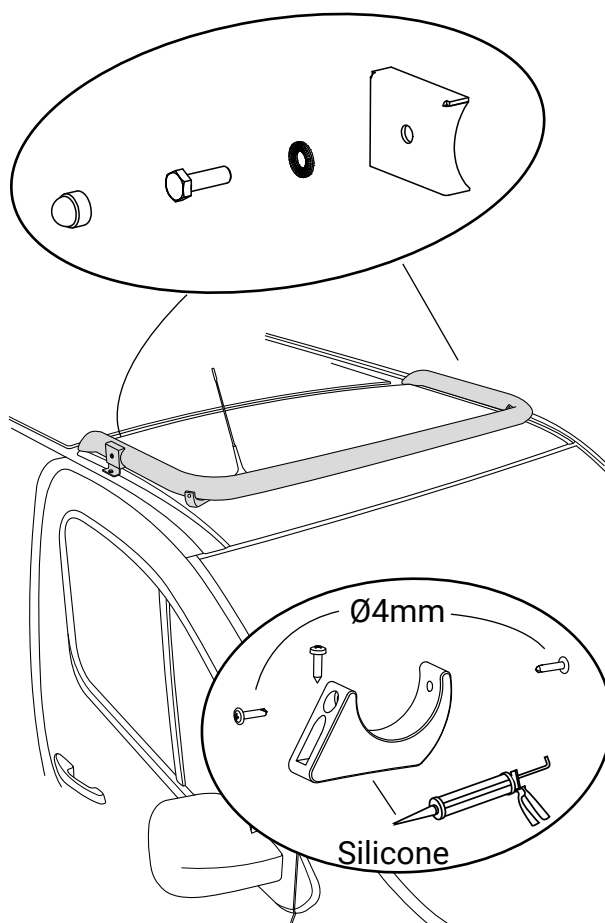
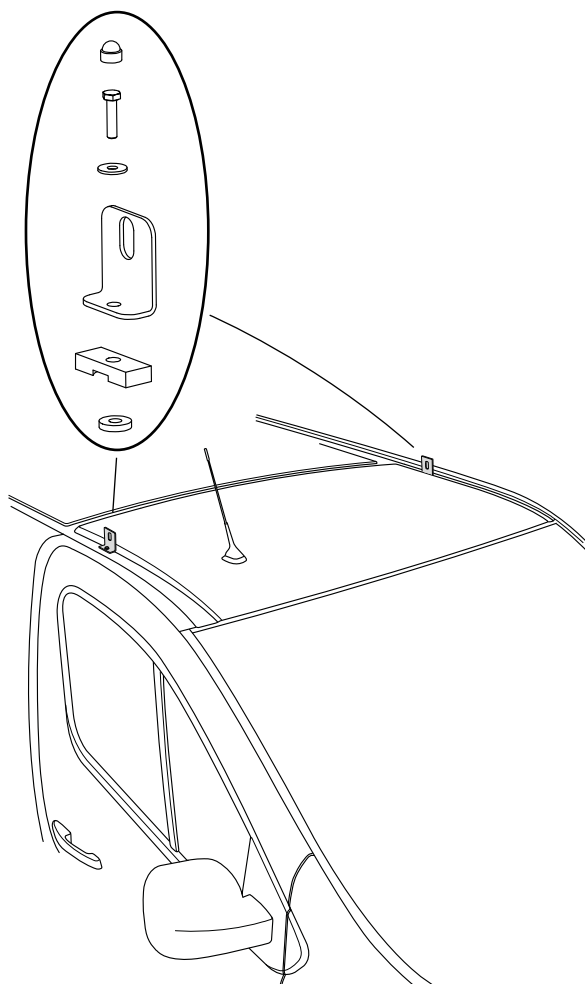
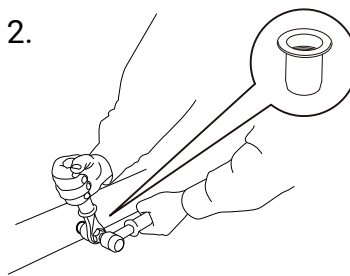

Nr	Ant	Ändring	Datum	Godk.
B		M8 Nitmutter & mellanlägg	2024-02-22	

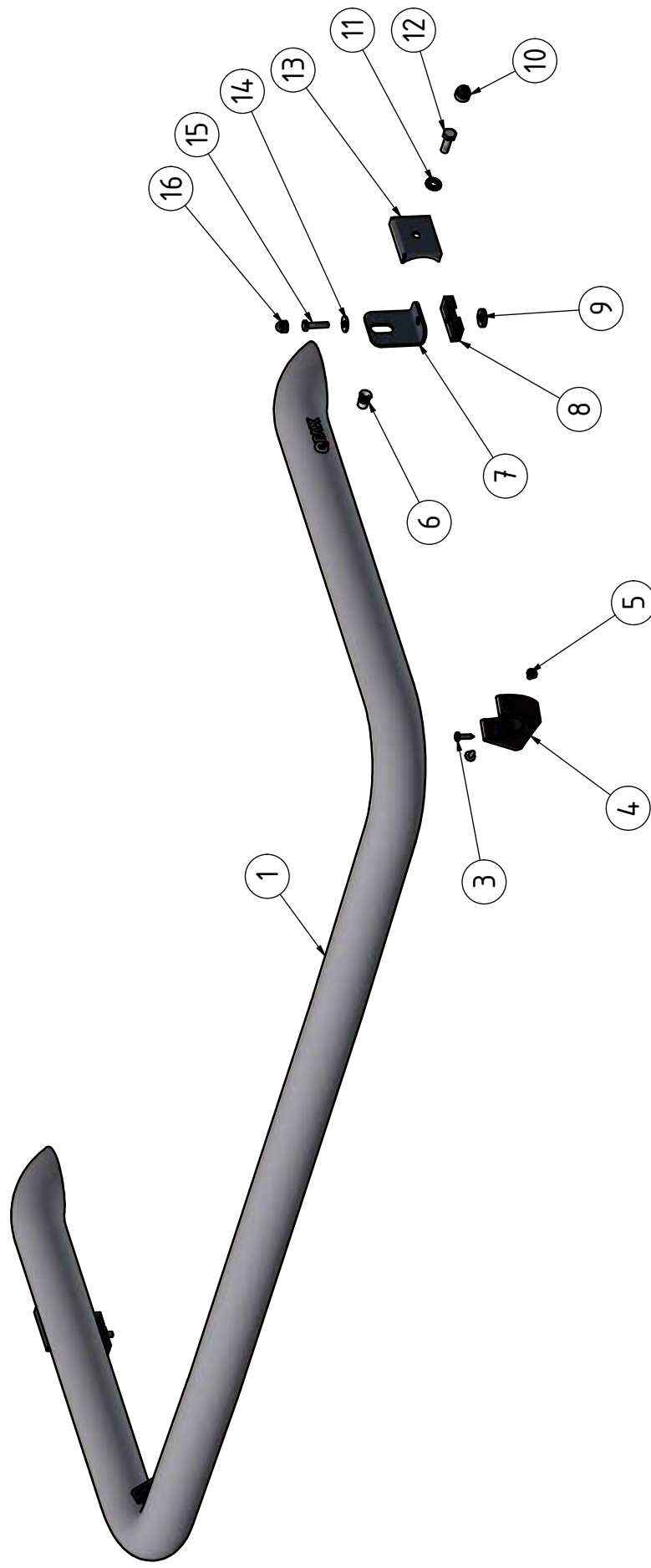

Pos	Ant	SMST Titel	Dimension	Artikel nr/Referens
16	2	Mutterskydd 10mm	M6	50942
15	2	Skruv M6S	M6x25	34118
14	2	Bricka M6 bred	6,4x18 x1,6	34304
13	2	Täcklock	T=2	100209
12	2	Skruv M6S	M8x25	34105
11	2	Bricka Nordlock M8 Bred	M8	34328
10	2	Mutterskydd 13mm	M8	50944
9	2	Tätningbricka	20x8x4	50935
8	2	Mellanlägg Unifäste	50x10x20	100142
7	2	Vinkel 43mm 90°	T=3	100270
6	2	Nitmutter M8 Alu	M8 Ø11mm 1,5-4,5	32211
5	4	Skruv MRT-TT	M5x10	34235
4	2	Magnetfäste	t=25	100141
3	2	Skruv RXS	4,2x19	34162
2	2	Dekal QPAX	54x17	60325
1	1	T-RACK främre takbåge	F92-752	

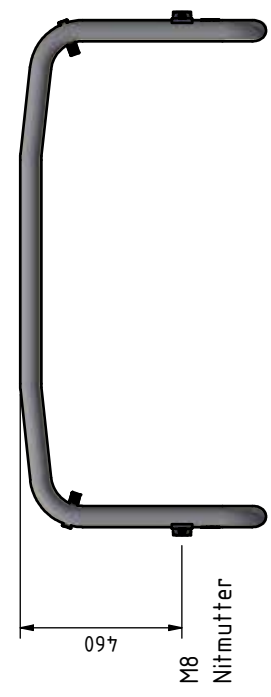

Konstr	Ritad	Kop.	Kontr.	Stand.	Godk.	Ersätter	Ersatt av
JNO	JNO					1 : 5	
Där ej annat anges, gäller SS-ISO 2768 - C och SMS 723 - B. S veckavärde för sveisar enligt SS - ISO 9817 nva C.							
				T-RACK Främre takbåge Traffic/Primastar			
Tel: +46 (0)651-760-1460		Mail: info@qpax.se		Art. nr		93498	
		Filnamn		Datum		Rev	
		93498.idw		2021-11-25		B	

Den här handlingen får inte kopieras utan vårt skriftliga medgivande och dess innehåll får inte yppas för tredje man och inte heller användas för något obehörigt ändamål.