



# CERTIFICATE OF COMPLIANCE

No. GER23D165E

**Holder of Certificate: GREE Electric Appliances Inc. of zhuhai**  
**Jinji West Road, Qianshan, Zhuhai, Guangdong 519070, P. R. China**  
**Product: Air conditioner**

**Model/Type:**

**GVH48ALXK-M6DNC7A**

**Is complied with:**

**EMC Directive: 2014/30/EU**

**Test acc. To: EN IEC 55014-1:2021**

**EN IEC 55014-2:2021**

**EN 61000-3-3:2013/A1:2019**

**EN IEC 61000-3-2:2019+A1:2021**

**Report Number: GER23D165E**

This certificate of conformity is based on the adequate technical documentation and the tests in Testing Laboratory of Gree Electric Appliances Inc. of Zhuhai. This declaration becomes invalid if technical or operational modifications are introduced without the manufacturer's consent.

Note: Testing Laboratory of Gree Electric Appliances Inc. of Zhuhai is accredited by TUV Rheinland, CNAS, VDE, etc.

(Authorized signature)

Name: Wu Hongqing

Date: 2023-04-05

# EMC TEST REPORT

**Product Name** : Air conditioner  
**Product Model** : GVH48ALXK-M6DNC7A  
**Serial No.** : Pre-production model  
**Date of Receipt** : 2023-04-03  
**Test Period** : 2023-04-03~2023-04-04  
**Applicant** : Gree Electric Appliances, Inc. of Zhuhai  
**Testing Location** : Gree EMC Testing Lab.

## Applicable The Following Selected Harmonized Standards:

EN IEC 55014-1:2021  
EN IEC 55014-2:2021  
EN 61000-3-3:2013/A1:2019  
EN IEC 61000-3-2:2019+A1:2021

<b>Tested by</b> :	Tang Peijie		2023-04-04
	<i>Printed Name</i>	<i>Signature</i>	<i>Date((YY-MM-DD))</i>
<b>Reviewed by</b> :	Wu Hongqing		2023-04-05
	<i>Printed Name</i>	<i>Signature</i>	<i>Date((YY-MM-DD))</i>

## EMC LABORATORY OF GREE ELETRIC APPLIANCES INC. OF ZHUHAI

Address: Jinji West Road. Qianshan Zhuhai China  
Tel: (0756) 8973423

Postcode: 519070  
Email: greezsykt@cn.gree.com

## Contents

<b>1. TEST SUMMARY .....</b>	<b>3</b>
<b>2. PRODUCTS DESCRIPTION .....</b>	<b>4</b>
<b>3. LIST OF TEST AND MEASUREMENT INSTRUMENTS.....</b>	<b>5</b>
<b>4. EMISSION TEST .....</b>	<b>6</b>
4.1 Main and Additional Terminal Continuous Disturbance Voltage .....	6
4.2 Discontinuous Interference on AC Mains .....	15
4.3 Disturbance Power.....	17
4.4 Harmonics on AC Mains .....	21
4.5 Voltage Fluctuation on AC Mains.....	28
4.6 Radiation emission .....	29
4.7 Measurement Uncertainty .....	31
<b>5. IMMUNITY TESTS .....</b>	<b>32</b>
5.1 Electrostatic Discharge (ESD).....	32
5.2 Electrical Fast Transient/Burst (EFT).....	34
5.3 Surge.....	35
5.4 Immunity to conducted Disturbances, induced by RF fields .....	37
5.5 Voltage Dips and Short interruptions.....	38
5.6 Radio-frequency electromagnetic field immunity.....	39

---

**Remark: Principle of Configuration Selection of test set-up and operation mode.**

**Emission:** The Equipment under test (EUT) was configured to measure its highest possible radiation level. The test modes were adapted accordingly in reference to the instructions for use.

**Immunity:** The Equipment under test (EUT) was configured to have its highest possible susceptibility against the tested phenomena. The test modes were adapted accordingly in reference to the instructions for use.

# 1. Test Summary

## 4. EMISSION TESTS:

### 4.1 Mains and additional Terminal Continuous Disturbance Voltage

**Test Result:** Pass

### 4.2 Discontinuous Interference on AC Mains

**Test Result:** Pass

### 4.3 Disturbance Power

**Test Result:** Pass

### 4.4 Harmonics on AC Mains

**Test Result:** Pass

### 4.5 Voltage Fluctuation on AC Mains

**Test Result:** Pass

### 4.6 Radiation emission

**Test Result:** Pass

## 5. IMMUNITY TESTS:

### 5.1 Electrostatic Discharge (ESD)

**Test Result:** Pass

### 5.2 Electrical Fast Transient/Burst (EFT)

**Test Result:** Pass

### 5.3 Surge

**Test Result:** Pass

### 5.4 Immunity to conducted Disturbances, induced by RF fields

**Test Result:** Pass

### 5.5 Voltage Dips and Short interruptions

**Test Result:** Pass

### 5.6 Radio-frequency electromagnetic field immunity

**Test Result:** Pass

## 2. Products Description

<b>Power Supply</b>	:	AC 380V~415V, 3P-50Hz
<b>Power Cord</b>	:	Unshielded
<b>Interconnection Line</b>	:	Unshielded
<b>Additional Equipment</b>	:	IR Remote Controller
<b>Protection</b>	:	Class I
<b>Operation Mode</b>	:	Cool Standby Fan Heat Dry Auto
<b>General Description</b>	:	

About the particular information of the modes, please refer to Technical Construction Document, user manual, etc.

Air conditioning products oscillator frequency is less than 30MHz, according to the requirement of EN 55014-1, because the disturbance power margin requirements meet the experiment, so do not need to do 300MHz~1000MHz radiation emission experiment.

Air conditioning products oscillator frequency is less than 15MHz, in accordance with the requirements of EN 55014-2, so do not need to do 80MHz~1000MHz radiation immunity test.

The cooling mode is the worst state of the test situation.

### 3. List of Test and Measurement Instruments

Equipment	Manufacturer	Model No.	Serial No.	Calibrated until
EMI Test Receiver	R&S	ESR3	102581	2023-06-30
Pulse limiter	R&S	ESH3-Z2	102732	2023-07-01
L.I.S.N	SCHWARZBECK	NNLK8121	06029	2023-07-01
Voltage Probe	R&S	ESH2-Z3	100595	2023-07-01
Absorbing Clamp	R&S	MDS-21	100642	2023-05-25
Clicks Analyzer	AFJ	DDA55	14041910125	2023-08-18
AFL LISN	AFJ	LS16C/10	16011920449	2023-06-30
EFT/Surge Generator	EMTEST	UCS500-N7	V1208111997	2023-06-30
EFT/Surge Generator	EMTEST	TSURGE	V1208111998	2023-06-30
Three-phase coupling/ decoupling network	EMTEST	CNI503	V1208111999	2023-06-30
Capacitive Coupling Clamp	EMTEST	HFK	0312-63	2023-06-30
Test System for Conducted and Radiated Immunity	TESEQ	NSG4070C-80	54282	2023-04-26
Cable	TESEQ	CBL2-BN-1.0m	223BN100003	2023-06-30
Coupling/Decoupling Network	TESEQ	CDN M332	54146	2023-04-26
Absorbing Clamp	SCHAFFNER	AMZ41	15583	2023-07-10
Harmonic, Flicker Testing system	EMTEST	AIF503N63	V1208112002	2024-03-22
Three-phase voltage drop simulator	TESEQ	NSG2200-3	A51773	2023-11-03
Harmonic, Flicker Testing system	EMTEST	ACS503N60	V1208112003	2023-07-18
ESD Simulator System	SCHLODER	SESD 30000A	004404	2023-06-12
Receiving antenna	SCHWARZBECK	VULB9163	9163-541	2023-08-30
Horn Antenna	R&S	HF907	102489	2023-08-10
RF Signal Generator	R&S	SMC100A	105529	2023-08-17
Power Meter	R&S	NRP2	104984	2023-12-07
Power Amplifier	R&S	BBA150	102087	2024-02-22
SVSWR	TDK	9X6X6m	EMC-3m-SAC	2023-10-25

## 4. Emission Test

### 4.1 Main and Additional Terminal Continuous Disturbance Voltage

<b>Date of testing</b>	:	2023-04-03
<b>Temperature</b>	:	26.6°C
<b>Operational mode</b>	:	Cool, High speed fan
<b>Humidity</b>	:	53.7%RH
<b>Test procedure</b>	:	EN IEC 55014-1:2021
<b>Frequency range</b>	:	0.15MHz~30MHz
<b>Kind of test site</b>	:	Shielded room
<b>Test result</b>	:	Pass

#### 1. Test Setup:

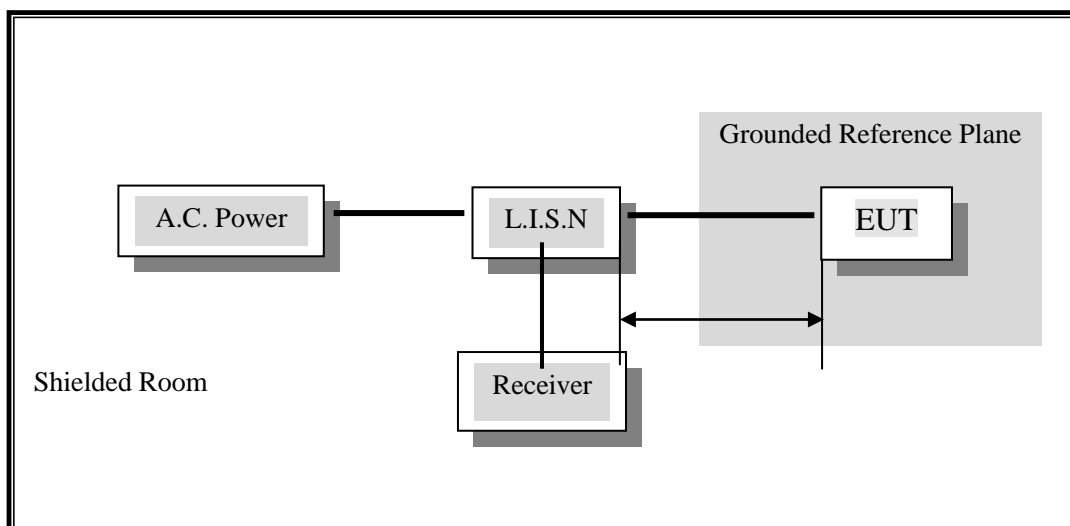

The EUT is on an insulating plane (height=80cm)

The distance between EUT and L.I.S.N is 80cm.

The distance between EUT and other metal conductors grounded is at least 80cm.

2.If the result of the measurement with the Quasi Peak detector is below the Average limit, the measurement with Average Detector has been omitted.

Disturbances other than those mentioned are small or not detectable.

Receiver setup:

**Detector:Peak+Average; IF-BW: 9kHz; Step: 4.5kHz; M-Time: 20ms**

The test data are as follows:

**At main terminal: Pass**

**Model: GVH48ALXK-M6DNC7A**

**Cooling mode Port: Power Cord, L1 line**

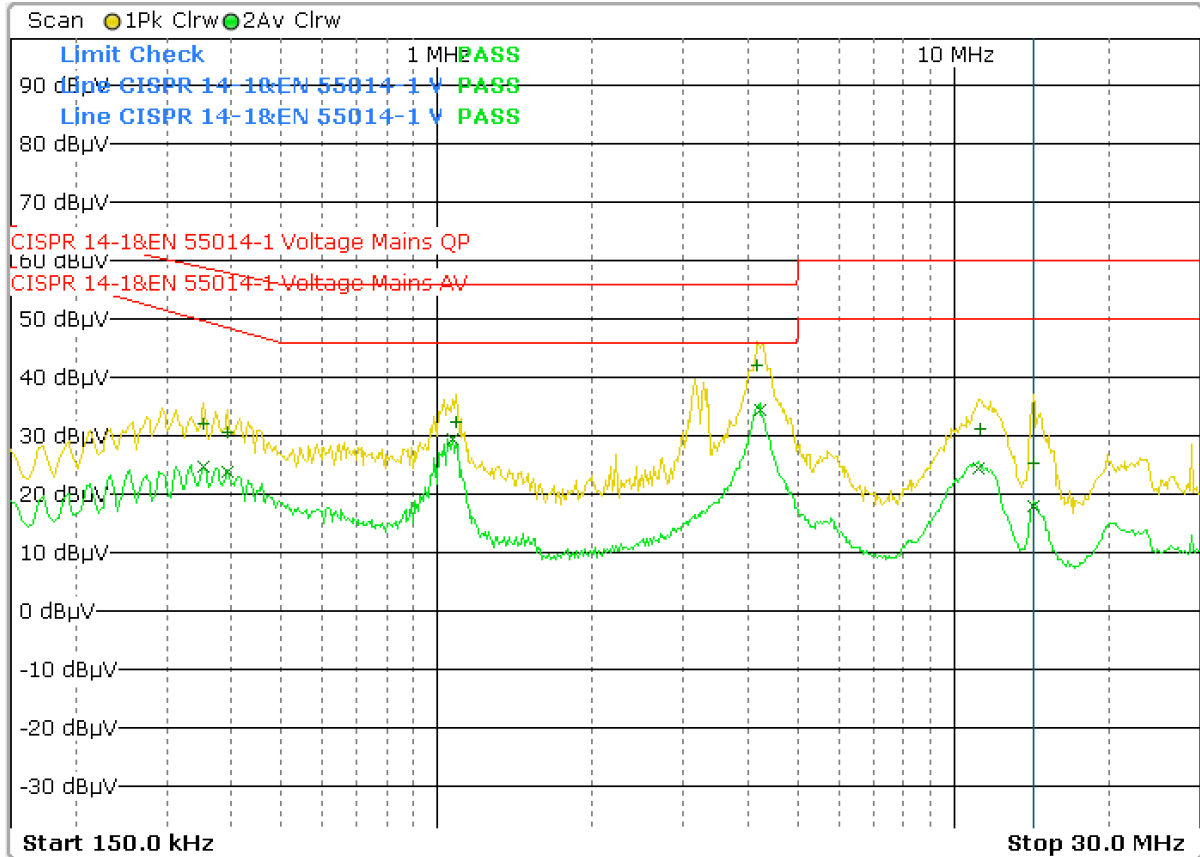

**Final measurement results**

Meas Time 1.0 s  
 Margin 60.0 dB  
 Peaks 6

Trace	Frequency	Level (dBµV)	Phase	Detector	Delta Limit/dB
1	354.00000000 kHz	32.01		Quasi Peak	-26.86
2	354.00000000 kHz	24.85		CISPR AV	-24.88
1	394.00000000 kHz	30.54		Quasi Peak	-27.44
2	394.00000000 kHz	23.77		CISPR AV	-24.80
2	1.070000000 MHz	29.43		CISPR AV	-16.57
1	1.090000000 MHz	32.46		Quasi Peak	-23.54
1	4.170000000 MHz	42.10		Quasi Peak	-13.90
2	4.214000000 MHz	34.45		CISPR AV	-11.55
2	11.182000000 MHz	24.44		CISPR AV	-25.56
1	11.242000000 MHz	31.18		Quasi Peak	-28.82
1	14.278000000 MHz	25.25		Quasi Peak	-34.75
2	14.278000000 MHz	17.87		CISPR AV	-32.13

**Cooling mode**                      **Port: Power Cord, L2 line**

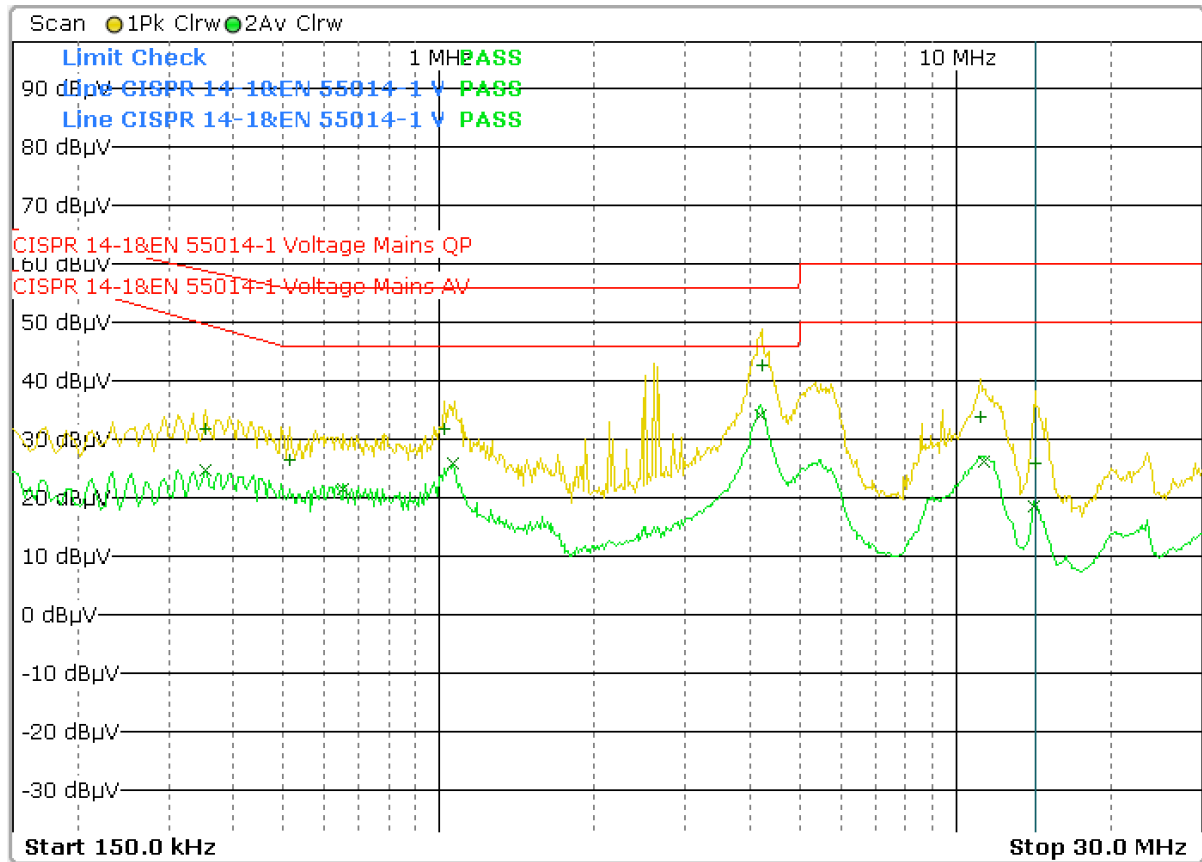

**Final measurement results**

Meas Time                      1.0 s  
 Margin                      60.0 dB  
 Peaks                      6

Trace	Frequency	Level (dBµV)	Phase	Detector	Delta Limit/dB
1	354.000000000 kHz	31.71		Quasi Peak	-27.16
2	354.000000000 kHz	24.78		CISPR AV	-24.95
1	514.000000000 kHz	26.50		Quasi Peak	-29.50
2	654.000000000 kHz	21.57		CISPR AV	-24.43
1	1.022000000 MHz	31.85		Quasi Peak	-24.15
2	1.062000000 MHz	25.88		CISPR AV	-20.12
2	4.178000000 MHz	34.29		CISPR AV	-11.71
1	4.210000000 MHz	42.78		Quasi Peak	-13.22
1	11.202000000 MHz	33.87		Quasi Peak	-26.13
2	11.322000000 MHz	26.36		CISPR AV	-23.64
2	14.206000000 MHz	18.47		CISPR AV	-31.53
1	14.270000000 MHz	26.02		Quasi Peak	-33.98

**Cooling mode**                      **Port: Power Cord, L3 line**

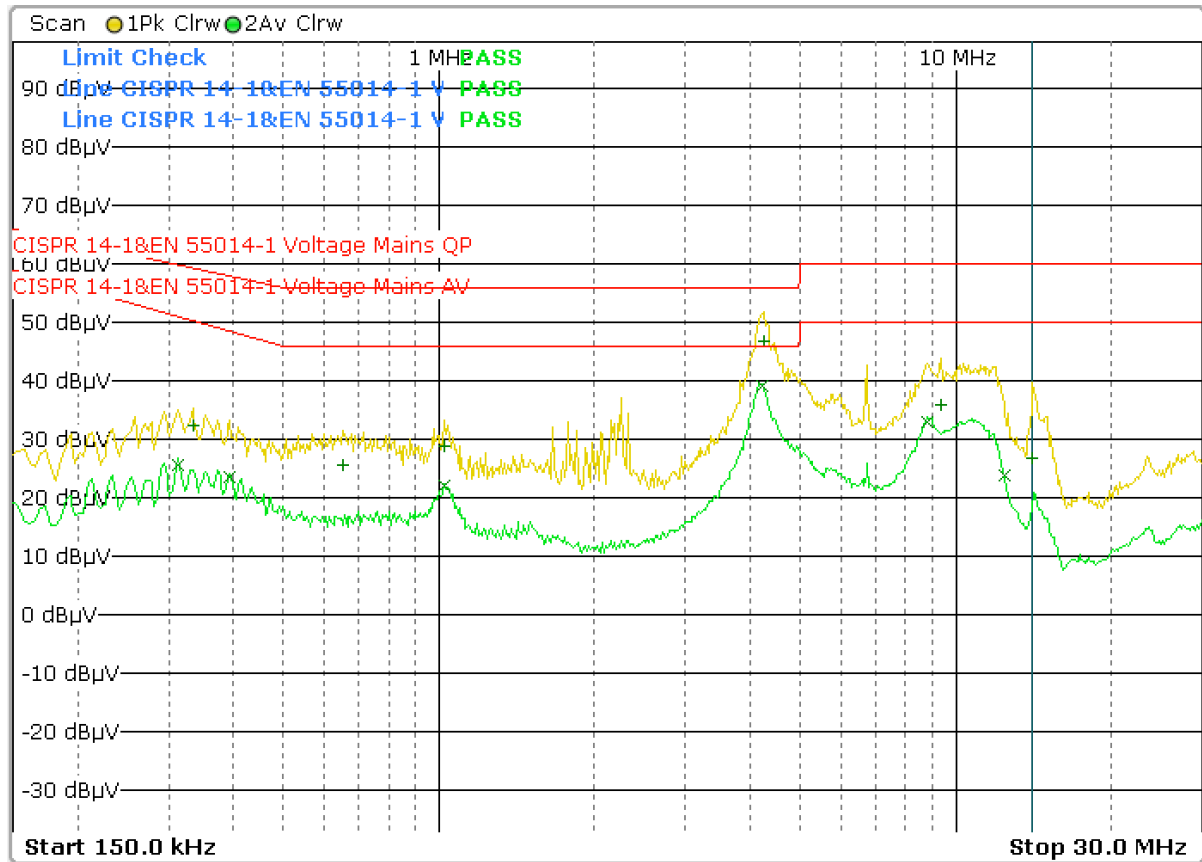

**Final measurement results**

Meas Time                      1.0 s  
 Margin                          60.0 dB  
 Peaks                            6

Trace	Frequency	Level (dBµV)	Phase	Detector	Delta Limit/dB
2	314.000000000 kHz	25.63		CISPR AV	-25.39
1	334.000000000 kHz	32.27		Quasi Peak	-27.08
2	394.000000000 kHz	23.58		CISPR AV	-24.99
1	650.000000000 kHz	25.69		Quasi Peak	-30.31
2	1.022000000 MHz	22.17		CISPR AV	-23.83
1	1.026000000 MHz	28.94		Quasi Peak	-27.06
2	4.214000000 MHz	39.28		CISPR AV	-6.72
1	4.250000000 MHz	46.92		Quasi Peak	-9.08
2	8.790000000 MHz	33.00		CISPR AV	-17.00
1	9.346000000 MHz	36.04		Quasi Peak	-23.96
2	12.426000000 MHz	23.96		CISPR AV	-26.04
1	14.098000000 MHz	26.85		Quasi Peak	-33.15

**Cooling mode**                      **Port: Power Cord, N line**

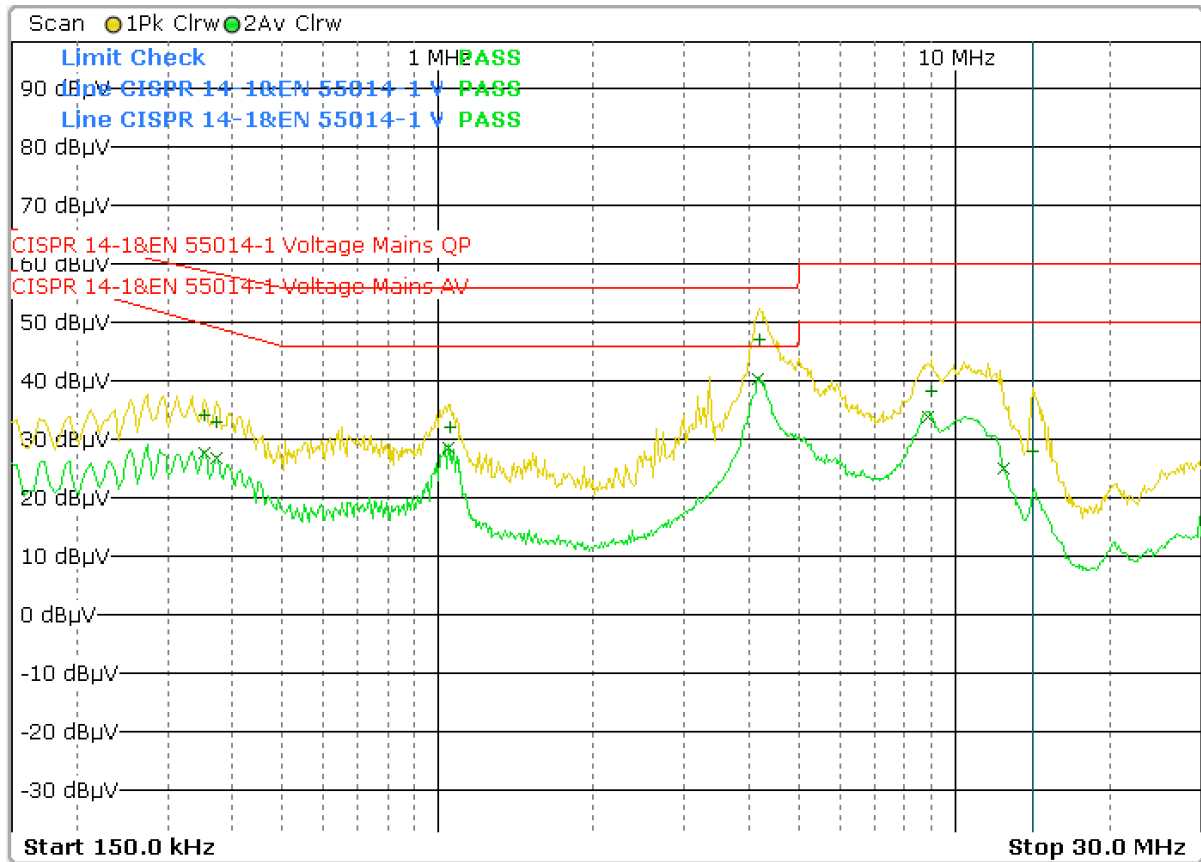

**Final measurement results**

Meas Time                      1.0 s  
 Margin                          60.0 dB  
 Peaks                            6

Trace	Frequency	Level (dBµV)	Phase	Detector	Delta Limit/dB
1	354.000000000 kHz	34.13		Quasi Peak	-24.74
2	354.000000000 kHz	27.66		CISPR AV	-22.07
1	374.000000000 kHz	32.94		Quasi Peak	-25.47
2	374.000000000 kHz	26.88		CISPR AV	-22.26
2	1.050000000 MHz	28.72		CISPR AV	-17.28
1	1.054000000 MHz	32.08		Quasi Peak	-23.92
2	4.170000000 MHz	40.24		CISPR AV	-5.76
1	4.178000000 MHz	47.08		Quasi Peak	-8.92
2	8.862000000 MHz	34.00		CISPR AV	-16.00
1	9.026000000 MHz	38.43		Quasi Peak	-21.57
2	12.422000000 MHz	25.11		CISPR AV	-24.89
1	14.214000000 MHz	27.95		Quasi Peak	-32.05



**Cooling mode**                      **Port: Interconnection line at indoor unit, Port B**

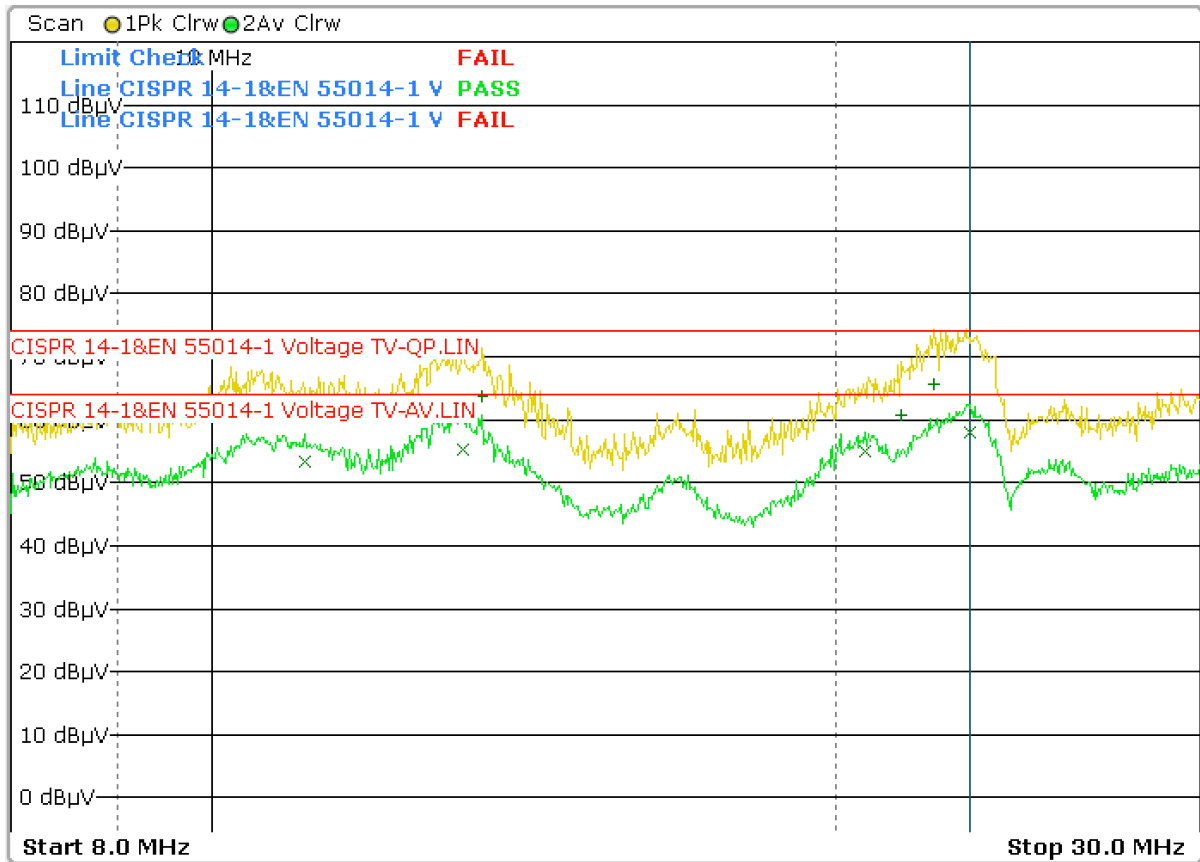

**Final measurement results**

Meas Time	1.0 s					
Margin	40.0 dB					
Peaks	1					
Trace	Frequency	Level (dBµV)	Phase	Detector	Delta	Limit/dB
1	10.212000000 MHz	61.21		Quasi Peak		-12.79
2	11.100000000 MHz	53.32		Average		-10.68
2	13.212000000 MHz	55.23		Average		-8.77
1	13.508000000 MHz	63.65		Quasi Peak		-10.35
2	20.664000000 MHz	54.89		Average		-9.11
1	21.536000000 MHz	60.84		Quasi Peak		-13.16
1	22.292000000 MHz	65.57		Quasi Peak		-8.43
2	23.228000000 MHz	57.89		Average		-6.11

**Cooling mode** **Port: Interconnection line at outdoor unit, Port A**

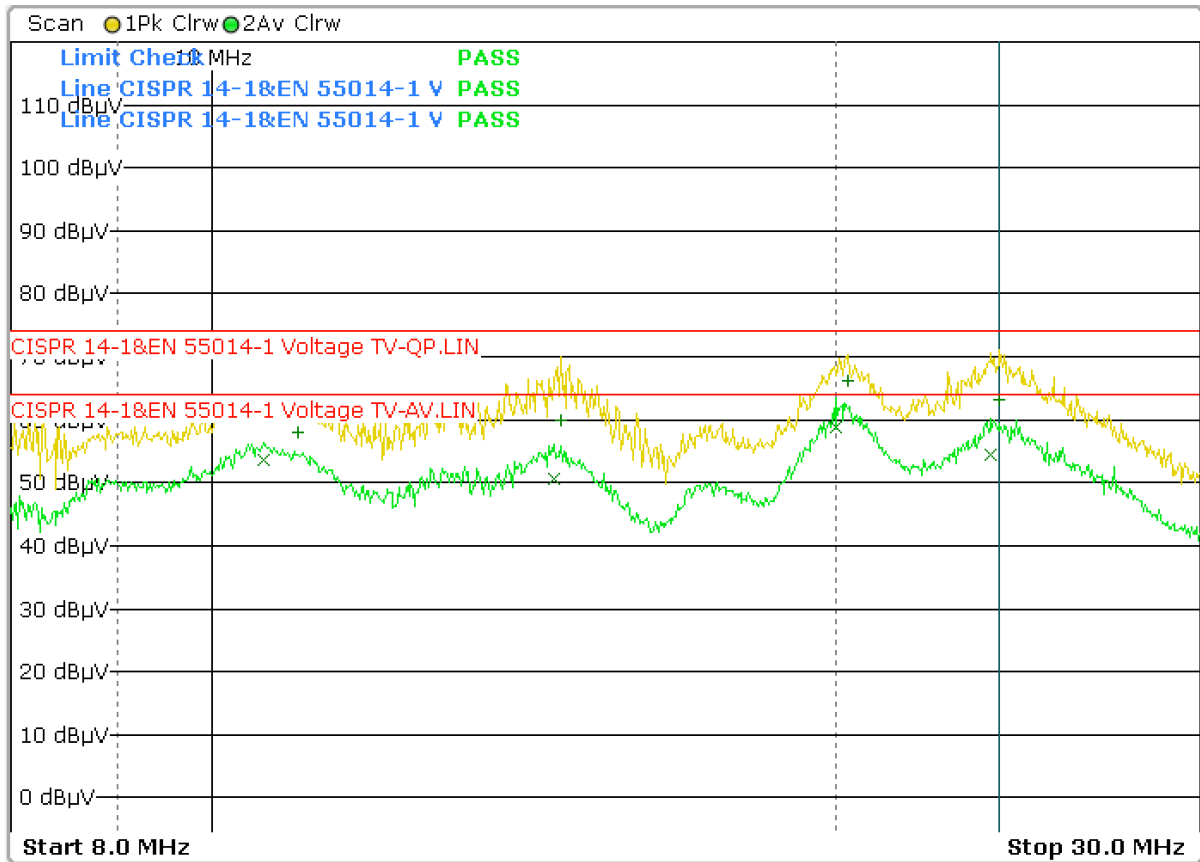

**Final measurement results**

Meas Time	1.0 s				
Margin	40.0 dB				
Peaks	1				
Trace	Frequency	Level (dBµV)	Phase	Detector	Delta Limit/dB
2	10.588000000 MHz	53.67		Average	-10.33
1	11.000000000 MHz	57.91		Quasi Peak	-16.09
2	14.624000000 MHz	50.67		Average	-13.33
1	14.736000000 MHz	59.78		Quasi Peak	-14.22
2	20.016000000 MHz	58.77		Average	-5.23
1	20.272000000 MHz	66.30		Quasi Peak	-7.70
2	23.784000000 MHz	54.40		Average	-9.60
1	24.008000000 MHz	63.20		Quasi Peak	-10.80

**Cooling mode Port: Interconnection line at outdoor unit, Port B**

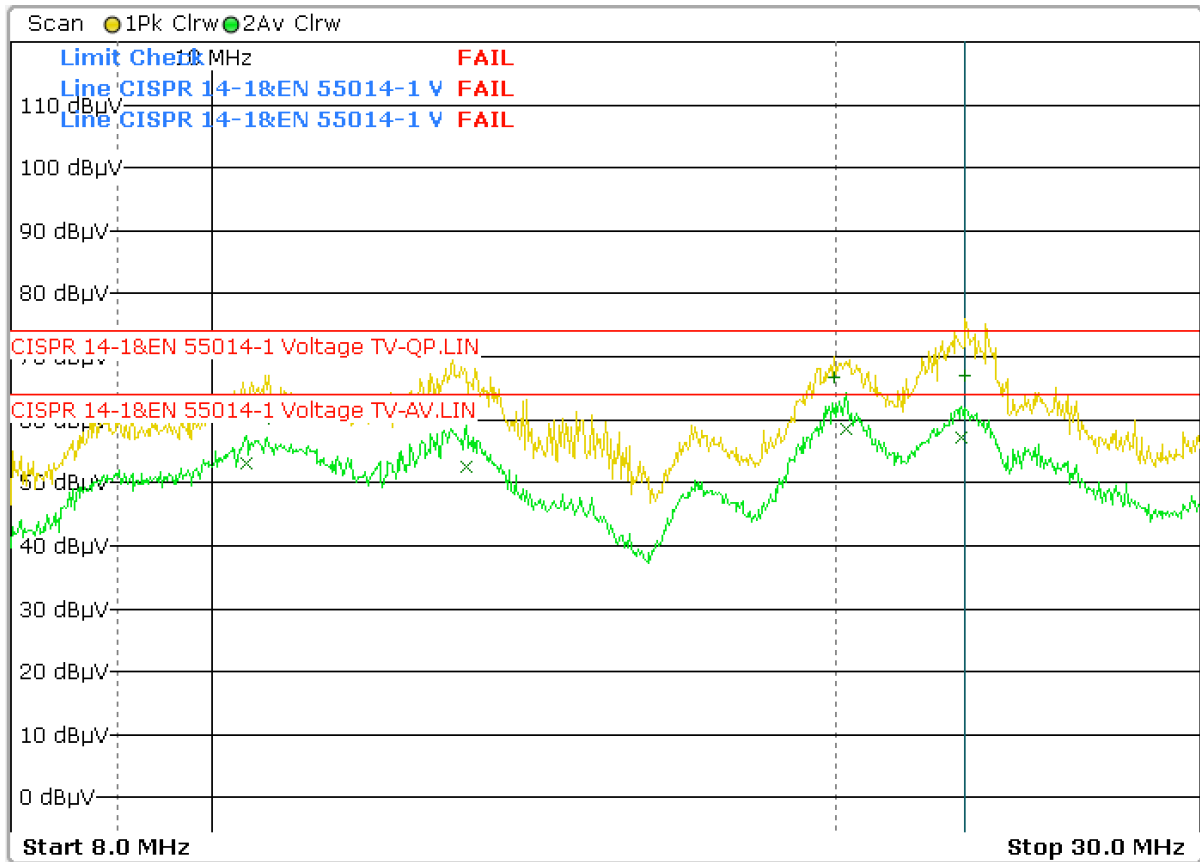

**Final measurement results**

Meas Time	1.0 s				
Margin	40.0 dB				
Peaks	1				
Trace	Frequency	Level (dBµV)	Phase	Detector	Delta Limit/dB
2	10.388000000 MHz	53.12		Average	-10.88
1	10.660000000 MHz	60.29		Quasi Peak	-13.71
1	13.068000000 MHz	62.82		Quasi Peak	-11.18
2	13.272000000 MHz	52.50		Average	-11.50
1	19.960000000 MHz	66.86		Quasi Peak	-7.14
2	20.260000000 MHz	58.48		Average	-5.52
2	23.020000000 MHz	57.29		Average	-6.71
1	23.112000000 MHz	66.89		Quasi Peak	-7.11

## 4.2 Discontinuous Interference on AC Mains

<b>Date of testing</b>	:	2023-04-03
<b>Temperature</b>	:	26.6°C
<b>Humidity</b>	:	56.3%RH
<b>Test procedure</b>	:	EN IEC 55014-1:2021
<b>Frequency range</b>	:	0.15MHz~30MHz
<b>Kind of test site</b>	:	Shielded room
<b>Operational mode</b>	:	Cool, High speed fan
<b>Test result</b>	:	Pass

### 1. Test Setup

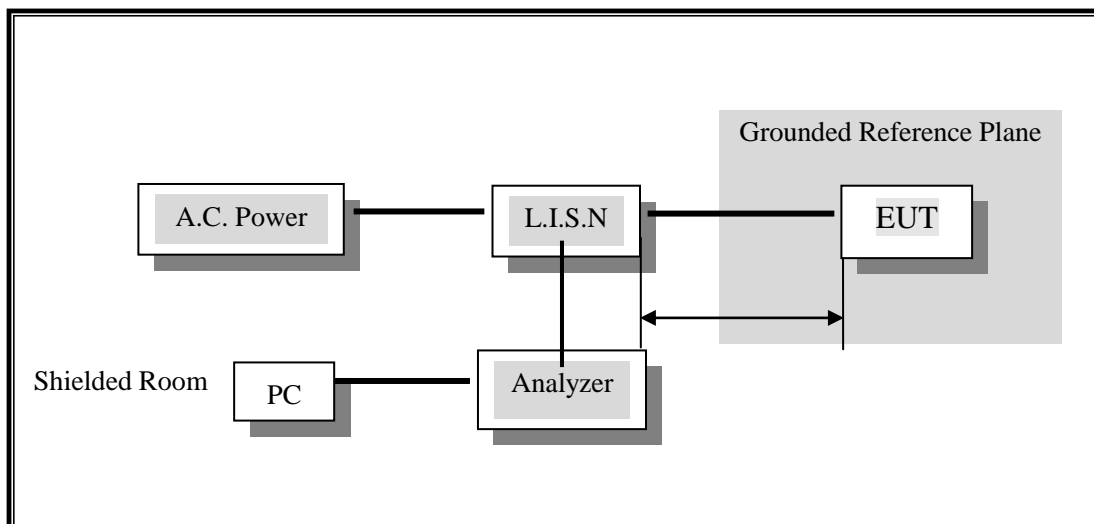

The EUT is on an insulating plane (height=80cm)

The distance between EUT and L.I.S.N is 80cm.

The distance between EUT and other metal conductors grounded is at least 80cm.

## 2. Test results.

<b>Model: GVH48ALXK-M6DNC7A</b>				
Run A (Observation time=120Mins0Sec)				
Frequency (MHz)	0.15	0.5	1.4	30
Limit value (L)(dB $\mu$ V)	66	56	56	60
Amount of clicks >L	Short (n1)	6	4	0
	Long (n2)	0	0	0
Total (n=n1+n2)	6	4	0	0
Click Rate (N=n/T)	0.05	0.03	0.00	0.00
Continuous(s)	0	0	0	0
Switching operations	---			
f factor	N/A			
Result	PASS			

### 4.3 Disturbance Power

<b>Date of testing</b>	: 2023-04-03
<b>Temperature</b>	: 26.6°C
<b>Operational mode</b>	: Cool, High speed fan
<b>Humidity</b>	: 53.7%RH
<b>Test procedure</b>	: EN IEC 55014-1:2021
<b>Frequency range</b>	: 30MHz~300MHz
<b>Kind of test site</b>	: Shielded room
<b>Test ports</b>	: AC Mains/ Interconnection line
<b>Test result</b>	: Pass

#### 1. Test Setup:

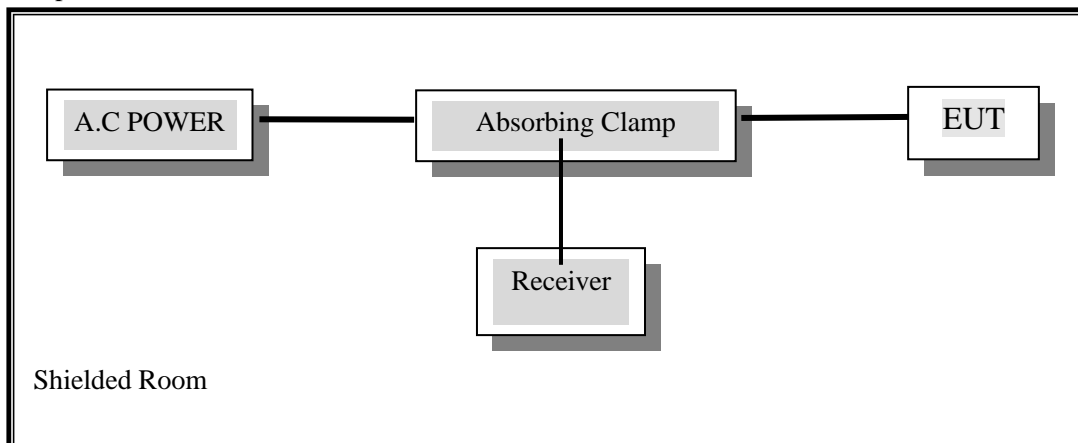

EUT and absorbing clamp are placed on an insulating plane (height=80cm). The distance between the absorbing clamp and other metal conductors grounded is 40cm above. EUT is connected to A.C power through an extended cord( $\cong$ 6m). The absorbing clamp clamps the power line and moves along the power line to measure the maximum disturbance power emitted from the line. If EUT has an indoors unit and an outdoors unit, its interconnection lines and signal lines(or controlling lines) should be also measured ,too.

2.If the result of the measurement with the Quasi Peak detector is below the Average limit, the measurement with Average Detector has been omitted.

The power cord and interconnection line had been extended to a length of 6m and routed through an absorbing clamp. The clamp was moved along the cable to find the maximal emission.

Disturbances other than those mentioned are small or not detectable.

Receiver setup:

**Detector:Peak+Average, IF-BW: 120kHz, Step: 60kHz, M-Time: 10ms.**

The frequency spectra are as follows:

**Model: GVH48ALXK-M6DNC7A**

**Cooling mode Port: Power Cord**

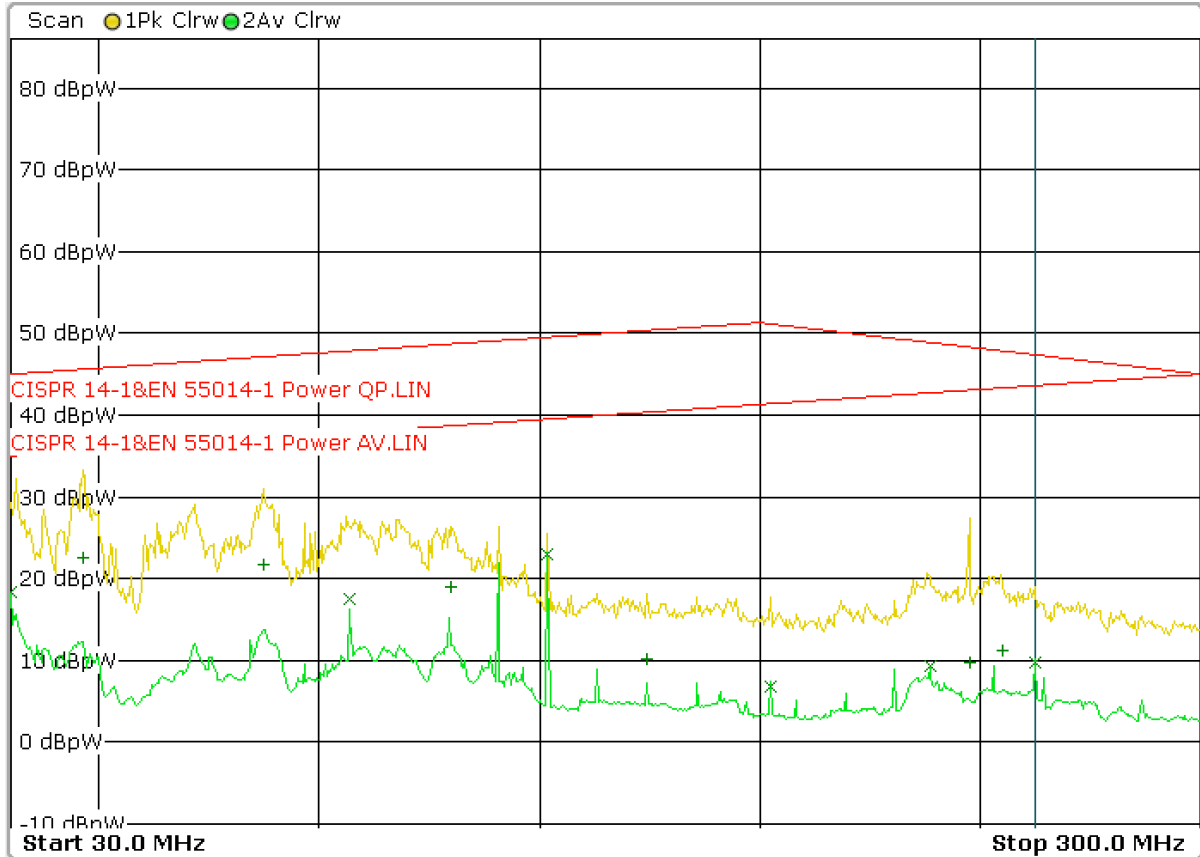

**Final measurement results**

Meas Time 1.0 s  
 Margin 60.0 dB  
 Peaks 6

Trace	Frequency	Level (dBpW)	Phase	Detector	Delta Limit/dB
2	30.00000000 MHz	18.35		Average	-16.65
1	46.48000000 MHz	22.55		Quasi Peak	-23.06
1	87.44000000 MHz	21.61		Quasi Peak	-25.52
2	106.88000000 MHz	17.55		Average	-20.30
1	130.04000000 MHz	19.07		Quasi Peak	-29.64
2	151.88000000 MHz	22.95		Average	-16.56
1	174.36000000 MHz	10.13		Quasi Peak	-40.22
2	202.56000000 MHz	6.73		Average	-34.66
2	238.76000000 MHz	9.37		Average	-33.36
1	247.64000000 MHz	9.82		Quasi Peak	-38.48
1	255.04000000 MHz	11.30		Quasi Peak	-36.53
2	262.60000000 MHz	9.67		Average	-33.94

**Cooling mode**                      **Port: Interconnection line at indoor unit**

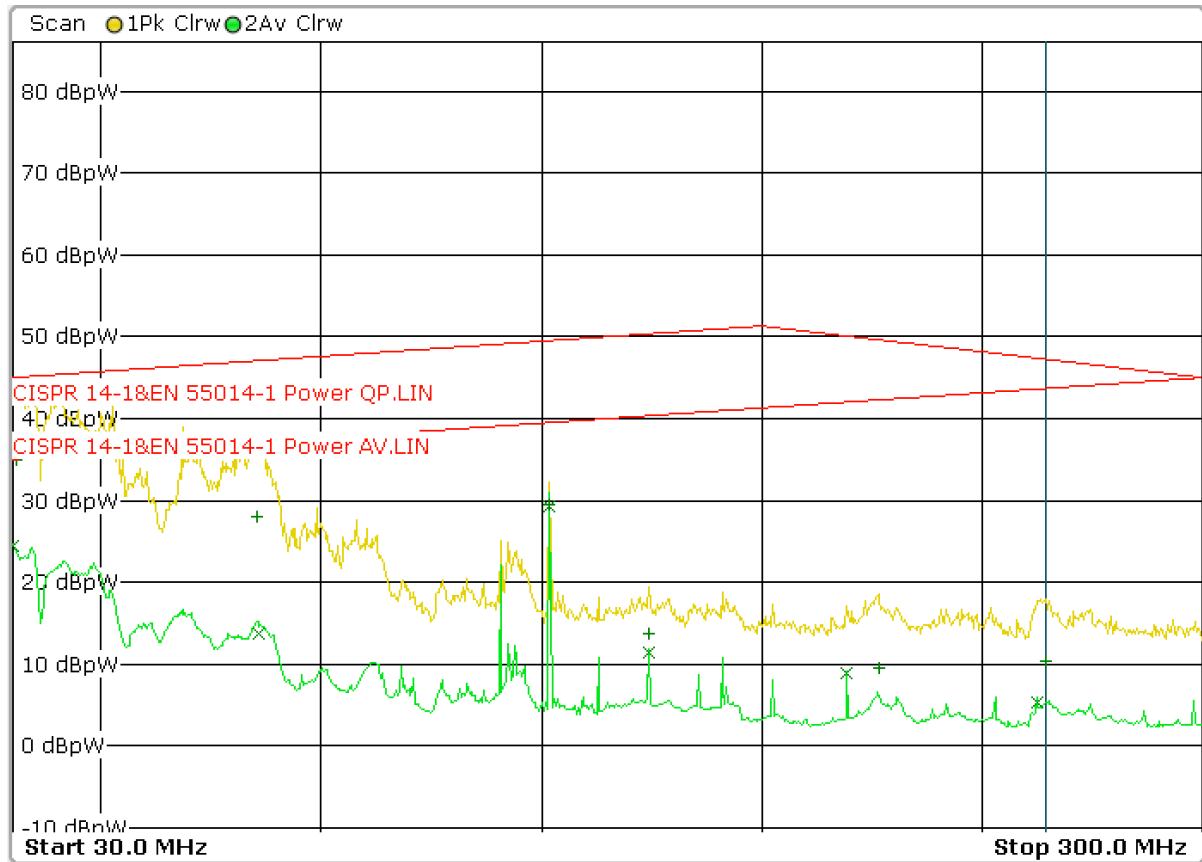

**Final measurement results**

Meas Time                      1.0 s  
 Margin                          60.0 dB  
 Peaks                            6

Trace	Frequency	Level (dBpW)	Phase	Detector	Delta Limit/dB
2	30.040000000 MHz	24.48		Average	-10.52
1	30.800000000 MHz	35.00		Quasi Peak	-10.03
1	85.320000000 MHz	28.09		Quasi Peak	-18.96
2	85.720000000 MHz	13.81		Average	-23.25
1	151.880000000 MHz	29.46		Quasi Peak	-20.06
2	151.880000000 MHz	29.33		Average	-10.18
1	174.360000000 MHz	13.74		Quasi Peak	-36.61
2	174.400000000 MHz	11.42		Average	-28.93
2	219.400000000 MHz	8.81		Average	-33.20
1	226.600000000 MHz	9.63		Quasi Peak	-39.99
2	262.520000000 MHz	5.42		Average	-38.19
1	264.400000000 MHz	10.43		Quasi Peak	-36.81



## 4.4 Harmonics on AC Mains

<b>Date of testing</b>	:	2023-04-03
<b>Temperature</b>	:	28.6°C
<b>Humidity</b>	:	56.3%RH
<b>Test procedure</b>	:	EN IEC 61000-3-2:2019+A1:2021
<b>Harmonics order</b>	:	2~40
<b>Equipment Class</b>	:	A
<b>Operational mode</b>	:	Cool, High speed fan
<b>Test result</b>	:	Pass

### 1. Test Setup:

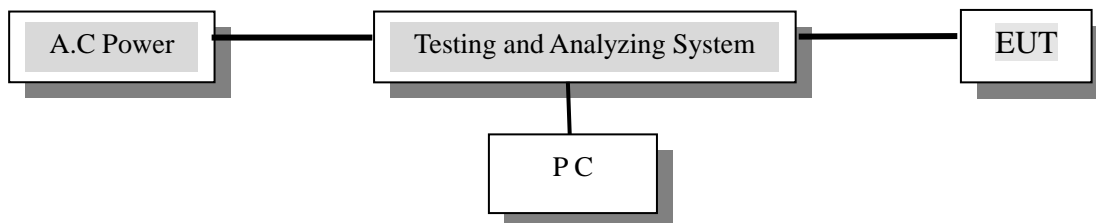

### 2. Test result.

**The test results are shown as follows:**

## Cooling mode

*Average harmonic current results - Phase 1*

Hn	I <sub>eff</sub> [A]	% of Limit	Limit [A]	Result
1	4.773			
2	3.969E-3			PASS
3	84.765E-3	3.685	2.30	PASS
4	3.305E-3			PASS
5	1.058	92.790	1.14	PASS
6	3.252E-3			PASS
7	473.783E-3	61.530	770.00E-3	PASS
8	2.035E-3			PASS
9	22.879E-3			PASS
10	1.933E-3			PASS
11	155.412E-3	47.095	330.00E-3	PASS
12	3.159E-3			PASS
13	85.906E-3	40.907	210.00E-3	PASS
14	2.143E-3			PASS
15	7.629E-3			PASS
16	1.609E-3			PASS
17	28.156E-3			PASS
18	1.768E-3			PASS
19	16.403E-3			PASS
20	1.947E-3			PASS
21	2.275E-3			PASS
22	1.930E-3			PASS
23	8.370E-3			PASS
24	1.590E-3			PASS
25	6.020E-3			PASS
26	1.509E-3			PASS
27	1.744E-3			PASS
28	1.484E-3			PASS
29	5.218E-3			PASS
30	1.647E-3			PASS
31	5.646E-3			PASS
32	1.703E-3			PASS
33	2.107E-3			PASS
34	1.519E-3			PASS
35	2.764E-3			PASS
36	1.553E-3			PASS
37	3.069E-3			PASS
38	1.533E-3			PASS
39	1.950E-3			PASS
40	1.577E-3			PASS

### Average harmonic current results - Phase 2

Hn	I <sub>eff</sub> [A]	% of Limit	Limit [A]	Result
1	6.690			
2	9.850E-3			PASS
3	1.225	53.254	2.30	PASS
4	5.533E-3			PASS
5	654.345E-3	57.399	1.14	PASS
6	3.885E-3			PASS
7	420.578E-3	54.621	770.00E-3	PASS
8	2.583E-3			PASS
9	63.688E-3	15.922	400.00E-3	PASS
10	2.250E-3			PASS
11	174.039E-3	52.739	330.00E-3	PASS
12	3.244E-3			PASS
13	139.878E-3	66.609	210.00E-3	PASS
14	2.396E-3			PASS
15	79.107E-3	52.738	150.00E-3	PASS
16	1.887E-3			PASS
17	31.467E-3			PASS
18	1.871E-3			PASS
19	66.673E-3	56.302	118.42E-3	PASS
20	2.177E-3			PASS
21	77.363E-3	48.138	160.71E-3	PASS
22	2.450E-3			PASS
23	75.682E-3	51.574	146.74E-3	PASS
24	2.314E-3			PASS
25	61.723E-3	45.721	135.00E-3	PASS
26	2.136E-3			PASS
27	39.210E-3			PASS
28	1.651E-3			PASS
29	7.160E-3			PASS
30	1.712E-3			PASS
31	14.898E-3			PASS
32	1.485E-3			PASS
33	7.682E-3			PASS
34	1.526E-3			PASS
35	3.585E-3			PASS
36	1.508E-3			PASS
37	3.238E-3			PASS
38	1.538E-3			PASS
39	2.728E-3			PASS
40	1.474E-3			PASS

### Average harmonic current results - Phase 3

Hn	I <sub>eff</sub> [A]	% of Limit	Limit [A]	Result
1	4.797			
2	4.666E-3			PASS
3	76.038E-3	3.306	2.30	PASS
4	3.395E-3			PASS
5	1.076	94.348	1.14	PASS
6	3.380E-3			PASS
7	473.866E-3	61.541	770.00E-3	PASS
8	2.031E-3			PASS
9	18.417E-3			PASS
10	2.194E-3			PASS
11	158.349E-3	47.984	330.00E-3	PASS
12	3.485E-3			PASS
13	83.797E-3	39.904	210.00E-3	PASS
14	2.510E-3			PASS
15	6.384E-3			PASS
16	1.618E-3			PASS
17	28.755E-3			PASS
18	1.855E-3			PASS
19	15.281E-3			PASS
20	1.733E-3			PASS
21	3.218E-3			PASS
22	2.075E-3			PASS
23	8.195E-3			PASS
24	1.637E-3			PASS
25	6.529E-3			PASS
26	1.551E-3			PASS
27	2.876E-3			PASS
28	1.544E-3			PASS
29	5.337E-3			PASS
30	1.665E-3			PASS
31	5.036E-3			PASS
32	1.630E-3			PASS
33	1.834E-3			PASS
34	1.552E-3			PASS
35	2.857E-3			PASS
36	1.510E-3			PASS
37	2.955E-3			PASS
38	1.529E-3			PASS
39	2.245E-3			PASS
40	1.549E-3			PASS

### Maximum harmonic current results - Phase 1

Hn	I <sub>eff</sub> [A]	% of Limit	Limit [A]	Result
1	4.877			
2	4.424E-3			PASS
3	85.824E-3	2.488	3.45	PASS
4	3.478E-3			PASS
5	1.058	61.899	1.71	PASS
6	3.417E-3			PASS
7	474.343E-3	41.069	1.15	PASS
8	2.142E-3			PASS
9	23.018E-3			PASS
10	2.032E-3			PASS
11	156.815E-3	31.680	495.00E-3	PASS
12	3.252E-3			PASS
13	86.716E-3	27.529	315.00E-3	PASS
14	2.242E-3			PASS
15	7.841E-3			PASS
16	1.704E-3			PASS
17	28.596E-3			PASS
18	1.900E-3			PASS
19	16.735E-3			PASS
20	2.054E-3			PASS
21	2.390E-3			PASS
22	2.000E-3			PASS
23	8.474E-3			PASS
24	1.681E-3			PASS
25	6.202E-3			PASS
26	1.607E-3			PASS
27	1.817E-3			PASS
28	1.528E-3			PASS
29	5.350E-3			PASS
30	1.734E-3			PASS
31	5.777E-3			PASS
32	1.826E-3			PASS
33	2.224E-3			PASS
34	1.649E-3			PASS
35	2.931E-3			PASS
36	1.618E-3			PASS
37	3.200E-3			PASS
38	1.584E-3			PASS
39	2.061E-3			PASS
40	1.655E-3			PASS

### *Maximum harmonic current results - Phase 2*

Hn	I <sub>eff</sub> [A]	% of Limit	Limit [A]	Result
1	6.816			
2	11.105E-3			PASS
3	1.226	35.544	3.45	PASS
4	6.212E-3			PASS
5	661.197E-3	38.667	1.71	PASS
6	4.161E-3			PASS
7	420.829E-3	36.435	1.15	PASS
8	2.853E-3			PASS
9	65.290E-3	10.882	600.00E-3	PASS
10	2.400E-3			PASS
11	178.846E-3	36.130	495.00E-3	PASS
12	3.334E-3			PASS
13	141.853E-3	45.033	315.00E-3	PASS
14	2.534E-3			PASS
15	80.269E-3	35.675	225.00E-3	PASS
16	1.982E-3			PASS
17	32.180E-3			PASS
18	1.973E-3			PASS
19	68.383E-3	38.497	177.63E-3	PASS
20	2.352E-3			PASS
21	77.561E-3	48.262	160.71E-3	PASS
22	2.600E-3			PASS
23	75.816E-3	51.665	146.74E-3	PASS
24	2.448E-3			PASS
25	62.168E-3	46.050	135.00E-3	PASS
26	2.232E-3			PASS
27	39.565E-3			PASS
28	1.758E-3			PASS
29	7.346E-3			PASS
30	1.817E-3			PASS
31	15.415E-3			PASS
32	1.629E-3			PASS
33	7.971E-3			PASS
34	1.602E-3			PASS
35	3.794E-3			PASS
36	1.613E-3			PASS
37	3.443E-3			PASS
38	1.640E-3			PASS
39	2.833E-3			PASS
40	1.545E-3			PASS

### Maximum harmonic current results - Phase 3

Hn	I <sub>eff</sub> [A]	% of Limit	Limit [A]	Result
1	4.902			
2	5.012E-3			PASS
3	76.220E-3	2.209	3.45	PASS
4	3.597E-3			PASS
5	1.076	62.939	1.71	PASS
6	3.627E-3			PASS
7	474.848E-3	41.112	1.15	PASS
8	2.127E-3			PASS
9	18.572E-3			PASS
10	2.314E-3			PASS
11	159.847E-3	32.292	495.00E-3	PASS
12	3.682E-3			PASS
13	84.768E-3	26.911	315.00E-3	PASS
14	2.649E-3			PASS
15	6.520E-3			PASS
16	1.737E-3			PASS
17	29.429E-3			PASS
18	1.950E-3			PASS
19	15.689E-3			PASS
20	1.815E-3			PASS
21	3.344E-3			PASS
22	2.183E-3			PASS
23	8.373E-3			PASS
24	1.715E-3			PASS
25	6.649E-3			PASS
26	1.669E-3			PASS
27	3.006E-3			PASS
28	1.654E-3			PASS
29	5.529E-3			PASS
30	1.765E-3			PASS
31	5.207E-3			PASS
32	1.714E-3			PASS
33	1.946E-3			PASS
34	1.630E-3			PASS
35	2.946E-3			PASS
36	1.634E-3			PASS
37	3.084E-3			PASS
38	1.686E-3			PASS
39	2.404E-3			PASS
40	1.611E-3			PASS

## 4.5 Voltage Fluctuation on AC Mains

<b>Date of testing</b>	: 2023-04-03
<b>Temperature</b>	: 28.6°C
<b>Humidity</b>	: 56.3%RH
<b>Test procedure</b>	: EN 61000-3-3:2013/A1:2019
<b>Frequency Range</b>	: 0Hz~2kHz
<b>Test observation period</b>	: 120min
<b>Operational mode</b>	: Cool, High speed fan
<b>Test result</b>	: Pass

### 1. Test Setup:

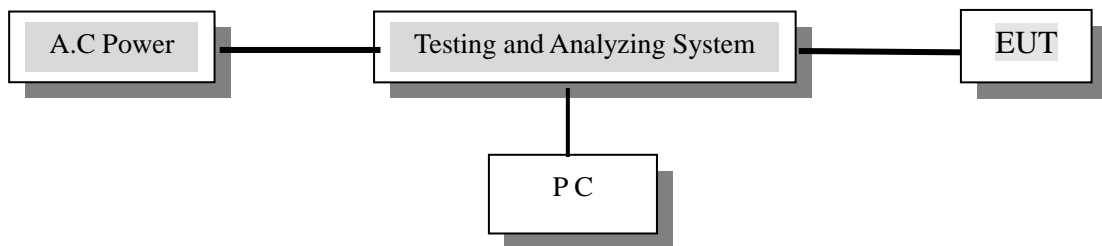

### 2. Test result.

Model		$d_c$ [%]	$d_{max}$ [%]	T-max[ms]	Pst	Plt
GVH48ALXK-M6DNC7A	L1	0.32	0.41	0.000	0.062	0.059
	L2	0.25	0.31	0.000	0.066	0.056
	L3	0.28	0.45	0.000	0.068	0.057
<b>Limit</b>		<b>3.30</b>	<b>6.00</b>	<b>500.0</b>	<b>1.000</b>	<b>0.650</b>

**Remark:**

## 4.6 Radiation emission

<b>Date of testing</b>	:	2023-04-03
<b>Temperature</b>	:	26.6°C
<b>Operational mode</b>	:	Cool, High speed fan
<b>Humidity</b>	:	56.3%RH
<b>Test procedure</b>	:	EN IEC 55014-1:2021
<b>Frequency range</b>	:	300MHz~1000MHz
<b>Measurement distance</b>	:	3m
<b>Kind of test site</b>	:	Semi-anechoic chamber
<b>Test result</b>	:	Pass

### 1. test setup

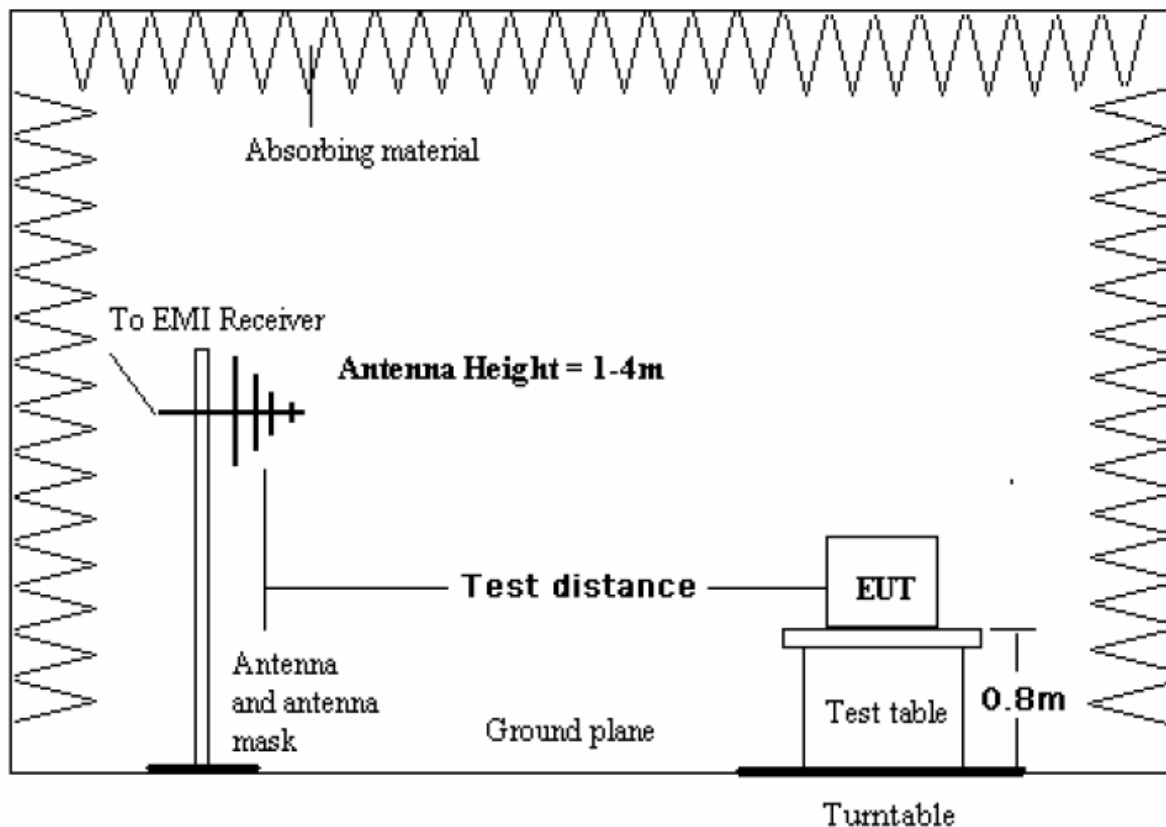

2. An initial pre-scan was performed in the 3m Semi-anechoic chamber using the spectrum analyzer in peak detection mode, Quasi-peak measurements were conducted based on the peak sweep graph. The EUT was measured by bilog antenna with two orthogonal polarities

The frequency spectra are as follows:

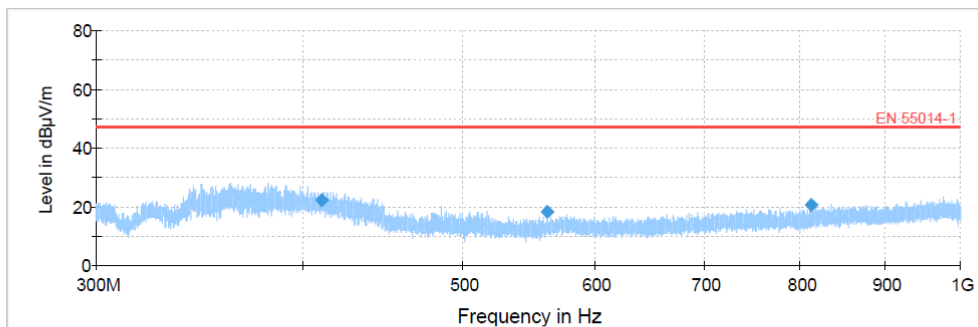

**Final Result**

Frequency (MHz)	QuasiPeak (dBµV/m)	Limit (dBµV/m)	Margin (dB)	Meas. Time (ms)	Bandwidth (kHz)	Height (cm)	Pol	Azimuth (deg)	Corr. (dB)	Comment
410.619231	22.28	47.00	24.72	1000.0	120.000	100.0	H	88.0	-19.9	
562.607692	18.37	47.00	28.63	1000.0	120.000	105.0	H	323.0	-17.8	
812.615385	20.50	47.00	26.50	1000.0	120.000	150.0	H	140.0	-14.3	

## 4.7 Measurement Uncertainty

The measurement uncertainty describes the overall uncertainty of the given measured value during the operation of the EUT

Measurement uncertainty is calculated in accordance with CISPR 16-4-2:2011+AMD1:2014+AMD 2:2018

Measurement uncertainty of mains terminal disturbance voltage in CISPR band B: 3.0dB

The measurement is given with a confidence of 95%, K=2

The measurement uncertainty for click test is under consideration according to CISPR 16-4-2:2011+AMD1:2014+AMD2:2018

The measurement uncertainty describes the overall uncertainty of the given measured value during the operation of the EUT

Measurement uncertainty is calculated in accordance with CISPR 16-4-2:2011+AMD1:2014+AMD 2:2018

Measurement uncertainty of mains terminal disturbance power: 3.3dB

The measurement is given with a confidence of 95%, K=2

The measurement uncertainty describes the overall uncertainty of the given measured value during the operation of the EUT

Measurement uncertainty is calculated in accordance with CISPR 16-4-2:2011+AMD1:2014+AMD 2:2018

Measurement uncertainty of radiated emission: 4.9dB

The measurement is given with a confidence of 95%, K=2

The measurement uncertainty for harmonic test is under consideration according to CISPR 16-4-2:2011+AMD1:2014+AMD2:2018

The measurement uncertainty for voltage fluctuation and flicker is under consideration according to CISPR 16-4-2:2011+AMD1:2014+AMD2:2018

## 5. Immunity Tests

### measurement uncertainty:

According to CISPR 16-4-2:2011+AMD1:2014+AMD2:2018 measurement uncertainty to immunity test is under consideration

### 5.1 Electrostatic Discharge (ESD)

<b>Date of testing</b>	:	2023-04-04
<b>Temperature</b>	:	26.6°C
<b>Humidity</b>	:	56.5%RH
<b>Test procedure</b>	:	EN IEC 55014-2:2021
<b>Basic Standard</b>	:	IEC 61000-4-2:2008
<b>Performance Criterion</b>	:	B
<b>Operational mode</b>	:	Cool, High speed fan
<b>Test result</b>	:	Pass

#### 1. Test setup

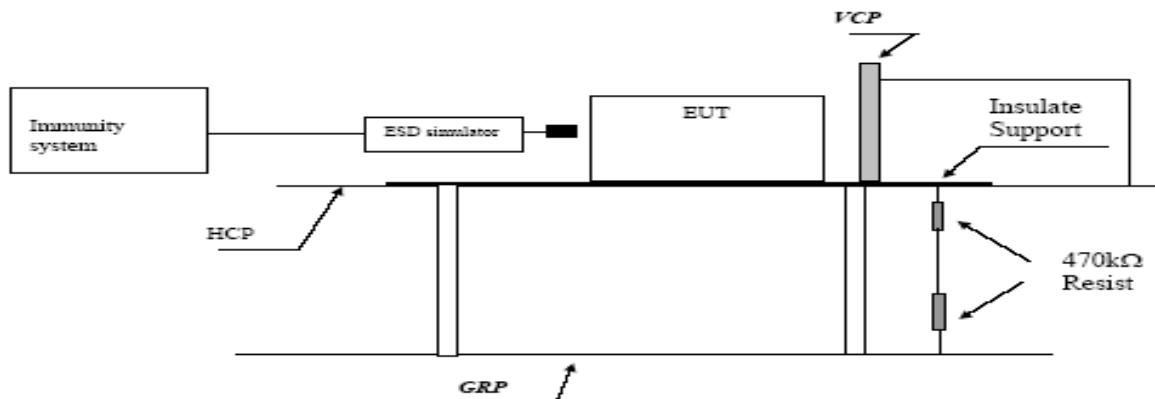

Note: HCP means Horizontal Coupling Plane,  
VCP means Vertical Coupling Plane  
GRP means Ground Reference Plane

The EUT was put on a 0.8m high wooden table/0.1m high for floor standing equipment standing on the ground reference plane (GRP) 3m by 2m in size, made by iron 1.0 mm thick.

A horizontal coupling plane (HCP) 1.6m by 0.8m in size was placed on the table, and the EUT with its cables were isolated from the HCP by an insulating support thick than 0.5mm. The VCP 0.5m by 0.5m in size & HCP were constructed from the same material type & thinness as that of the GRP, and connected to the GRP via a 470kΩ resistor at each end.

The distance between EUT and any of the other metallic surface excepted the GRP, HCP & VCP was greater than 1m.

The EUT was arranged and connected according to its functional requirements.

Direct static electricity discharges was applied only to those points and surface which are accessible to personnel during normal usage.

## 2. Test result

Location of Discharge	Type of Discharge	Level(kV)	Polarity	Number of Discharge	Result
Remote Receiver	Air	8.0	±	10	A
Display window	Air	8.0	±	10	A
Manual key	Air	8.0	±	10	A
Touchable screw	Contact	4.0	±	10	A
Remote Controller	Air	8.0	±	10	A
	HCP	4.0	±	10	A
	VCP	4.0	±	10	A
<b>Remark:</b> The Air discharge could not occur and the EUT worked normally during the test, no degradation of function occurred.					

Air -Air Discharge

Contact -Contact Discharge

HCP—Horizontal Coupling Plate,

VCP—Vertical Coupling Plate

## 5.2 Electrical Fast Transient/Burst (EFT)

<b>Date of testing</b>	:	2023-04-04
<b>Temperature</b>	:	26.5°C
<b>Humidity</b>	:	56.7%RH
<b>Test procedure</b>	:	EN IEC 55014-2:2021
<b>Basic Standard</b>	:	IEC 61000-4-4:2012
<b>Repetition Frequency</b>	:	5kHz
<b>Performance Criterion</b>	:	B
<b>Operational mode</b>	:	Cool, High speed fan
<b>Test result</b>	:	Pass

### 1. Test Setup

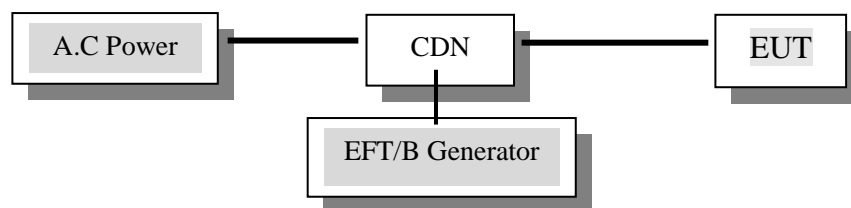

The EUT is placed on an insulating plane, it is 0.1m high for table model and 0.1m high for floor type above the grounded reference plane. EUT is at least 0.5m away from the wall of the EMC laboratory and other metal conductors grounded except the grounded reference plane., and its four borders are at least 0.1m away from the borders of the grounded reference plane. The cable between EUT and CDN is not more than 0.5m.

For signal lines and control lines, the burst signal is coupled by a capacitive coupling clamp.

### 2. Test result:

Location	Voltage(kV)	Duration(s)	Coupled by	Result
L1+L2+L3+N+PE	±1	120	CDN	A
Signal	±0.5	120	Capacitive Coupling Clamp	A
<b>Remark:</b> The EUT worked normally during the test, no degradation of function occurred.				

### 5.3 Surge

<b>Date of testing</b>	:	2023-04-04
<b>Temperature</b>	:	26.5°C
<b>Humidity</b>	:	56.7%RH
<b>Test procedure</b>	:	EN IEC 55014-2:2021
<b>Basic Standard</b>	:	IEC 61000-4-5:2014+AMD1:2017
<b>Performance Criterion</b>	:	B
<b>Operational mode</b>	:	Cool, High speed fan
<b>Test result</b>	:	Pass

#### 1. Test Setup

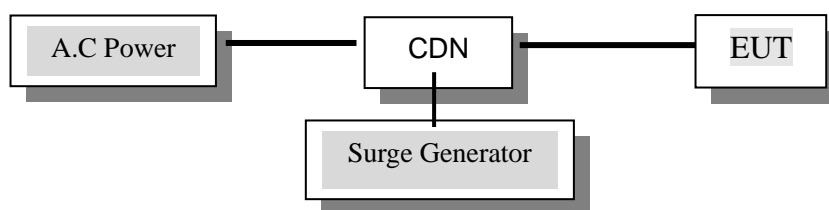

The cable between EUT and CDN is not more than 1m.  
No other special specifications.

## 2. Test result

Location	Polarity	Surge interval	Phase Angle	Number of test	Pulse Voltage (kV)	Result
L1—L2	+	60s	90°	5	1	A
	-	60s	270°	5	1	A
L1—L3	+	60s	90°	5	1	A
	-	60s	270°	5	1	A
L2—L3	+	60s	90°	5	1	A
	-	60s	270°	5	1	A
L1—N	+	60s	90°	5	1	A
	-	60s	270°	5	1	A
L2—N	+	60s	90°	5	1	A
	-	60s	270°	5	1	A
L3—N	+	60s	90°	5	1	A
	-	60s	270°	5	1	A
L1—PE	+	60s	90°	5	2	A
	-	60s	270°	5	2	A
L2—PE	+	60s	90°	5	2	A
	-	60s	270°	5	2	A
L3—PE	+	60s	90°	5	2	A
	-	60s	270°	5	2	A
N—PE	+	60s	90°	5	2	A
	-	60s	270°	5	2	A

**Remark:** The EUT worked normally during the test, no degradation of function occurred.

## 5.4 Immunity to conducted Disturbances, induced by RF fields

<b>Date of testing</b>	:	2023-04-04
<b>Temperature</b>	:	26.5°C
<b>Humidity</b>	:	56.7%RH
<b>Test procedure</b>	:	EN IEC 55014-2:2021
<b>Basic Standard</b>	:	IEC 61000-4-6:2013
<b>Frequency range</b>	:	150kHz~230MHz
<b>Modulation</b>	:	80%AM, 1kHz sine-wave
<b>Dwell time/Step size</b>	:	3000ms /1%
<b>Performance Criterion</b>	:	A
<b>Operational mode</b>	:	Cool, High speed fan
<b>Test result</b>	:	Pass

### 1. Test Setup

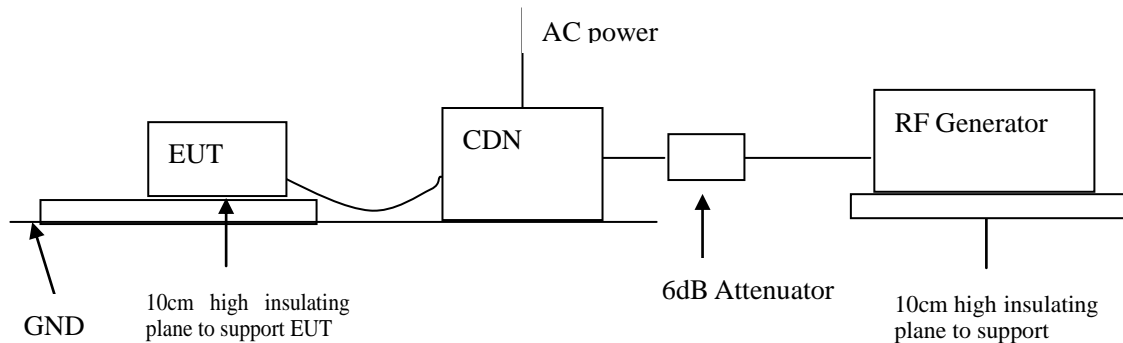

Frequency Range	Coupling Port	Strength	Coupling Method	Result
0.15MHz~80MHz	AC Mains	3V	CDN	A
80MHz~230MHz	AC Mains	3V	CDN	A
0.15MHz~80MHz	Signal	1V	Coupling/Decoupling Network	A
80MHz~230MHz	Signal	1V	Coupling/Decoupling Network	A
<b>Remark:</b> The EUT worked normally during the test, no degradation of function occurred.				

## 5.5 Voltage Dips and Short interruptions

<b>Date of testing</b>	:	2023-04-04
<b>Temperature</b>	:	26.5°C
<b>Humidity</b>	:	56.7%RH
<b>Test procedure</b>	:	EN IEC 55014-2:2021
<b>Basic Standard</b>	:	IEC 61000-4-11:2020
<b>Performance Criterion</b>	:	C
<b>Operational mode</b>	:	Cool, High speed fan
<b>Test result</b>	:	Pass

### 1. Test Setup

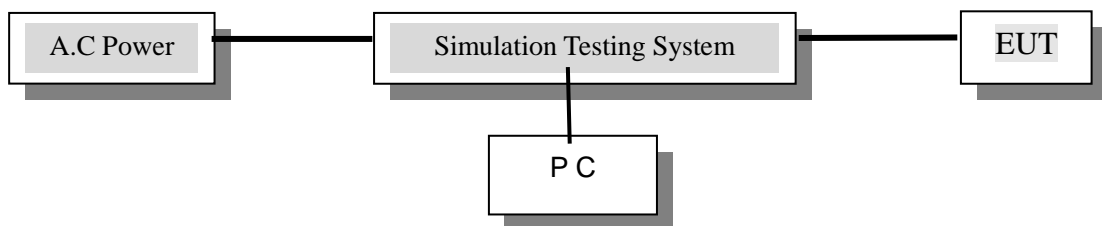

No other special specifications.

### 2. Test result.

Severity Level		Test Level	Duration	Intervals	Phase Angle	Number of Test	Result
Short Interruption 100%		0% $U_T$	0.5P	3min	0°	3	A
					180°	3	A
Voltage Dips	60%	40% $U_T$	10P	3min	0°	3	B
					180°	3	B
	30%	70% $U_T$	25P	3min	0°	3	B
					180°	3	B

#### Remark:

1,  $U_T$ : Nominal Voltage of EUT.

2, During the test of 40%  $U_T$ , 70%  $U_T$  the EUT stopped, but it could recover the primal status. No degradation of function occurred.

## 5.6 Radio-frequency electromagnetic field immunity

<b>Date of testing</b>	:	2023-04-04
<b>Temperature</b>	:	26.5°C
<b>Operational mode</b>	:	Cool, High speed fan
<b>Humidity</b>	:	56.7%RH
<b>Test procedure</b>	:	EN IEC 55014-2:2021
<b>Frequency range</b>	:	80MHz~1000MHz
<b>Modulation</b>	:	80%AM, 1kHz sine-wave
<b>Dwell time/Step size</b>	:	3000ms / 1%
<b>Performance Criterion</b>	:	A
<b>Measurement distance</b>	:	3m
<b>Kind of test site</b>	:	Semi-anechoic chamber
<b>Test result</b>	:	Pass

### 1.test setup

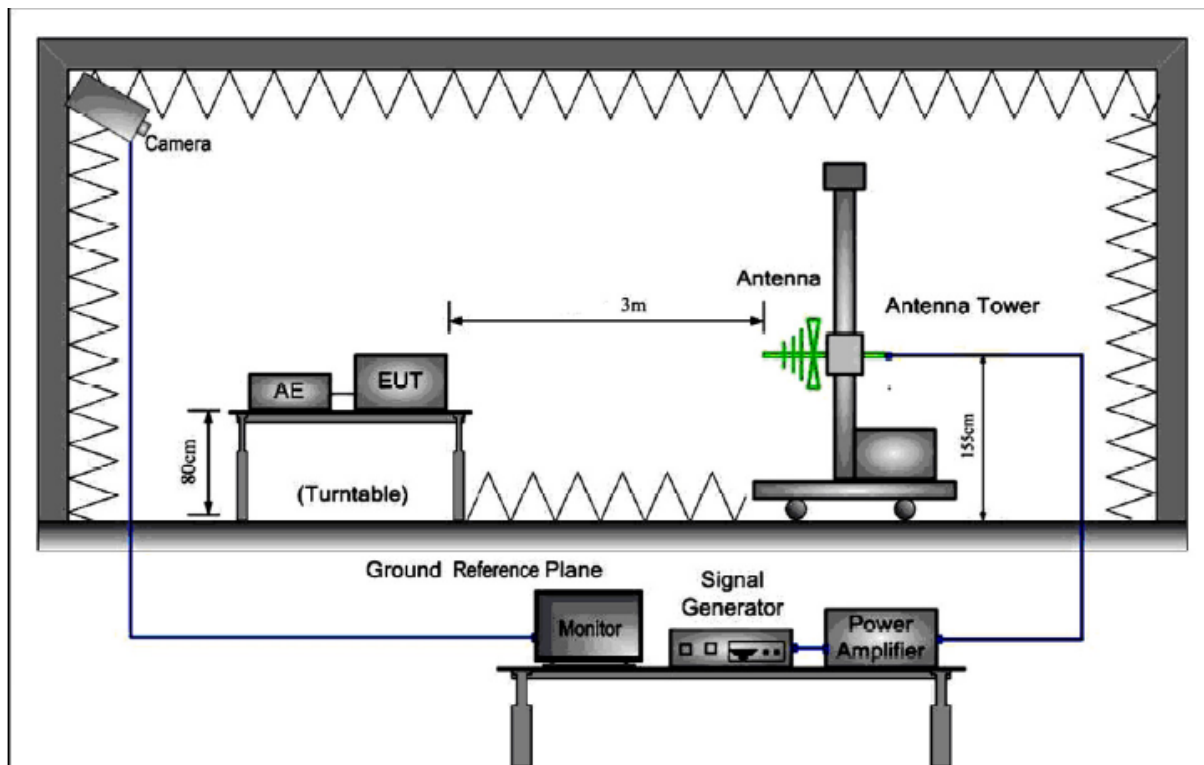

For table-top equipment, the EUT was placed in the chamber on a non-conductive table 0.8m high, for arrangement of floor-standing equipment, the EUT was mounted on a non-conductive support 0.1m above the supporting plane, a minimum of 1m of cable is exposed to the electromagnetic field, excess

length of cables interconnecting units of the EUT shall be bundled low-inductively in the approximate center of the cable to form a bundle 30cm to 40 cm in length, the EUT was initially placed with one face coincident with the calibration plane, the EUT face being illuminated was contained within the UFA(Uniform Field Area),where the frequency range was swept incrementally, the step size was not exceed 1% of the preceding frequency value, the dwell time of the amplitude modulated carrier at each frequency was not be less than the time necessary for the EUT to be exercised and to respond, and was not less 0.5s the test normally was performed with the generating antenna necessitates testing each selected side twice, once with the antenna positioned vertically and again with the antenna positioned horizontally, the EUT was performed in a configuration to actual installation conditions, a video camera monitor were used to monitor the performance of the EUT.

## 2. Test results

Frequency	Level	Modulation	Antenna Polarization	EUT Face	Results
80MHz~1GHz	3V/m	1kHz,80% AM, 1%increment	V	Front	A
			H		
			V	Rear	A
			H		
			V	Left	A
			H		
			V	Right	A
			H		

**Remarks:**  
 The front of the EUT faces to transmitting antenna  
 A:No degradation in the performance of the EUT was observed, No unintentional transmissions were observed