

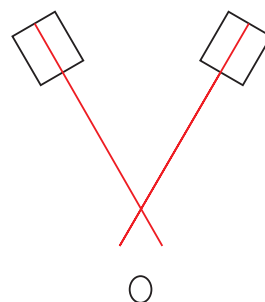

E100HD MKII

Esoteric Audio Devices Sweden AB



*Set up suggestion; Off axis,
crossing in front of listener.*

With the capacity to embrace a range of nine octaves in a system, the E100HD MKII offers among the widest bandwidth of any single drive unit on the market. This not only provides a seamless, crossover free sound, but allows for a wide range of applications and simplifies high quality designs as well.

The E100HD can be successfully used with all types of enclosures including closed or vented boxes, transmission lines and horn loaded designs. It is very suitable for high quality, home cinema, hifi and custom installations.

The rise above 4KHz can advantageously be compensated by using a toe in and off axis listening (see illustration above, axis crossing in front of listener), which widens the horizontal soundstage as well.

As a full range unit, the E100HD is also very sui-

table for 2 or 3 way systems, e.g. crossing over to a ribbon unit, where the wide band performance simplifies a 1st order cross over and the aluminium cone blends in seamlessly with the ribbon unit.

The main difference between the E100 and E100HD is the Cu capped pole piece, carefully selected to meet our specifications. This extends and improves the high frequency response to 25KHz, reduces high frequency impedance, Eddy currents as well as distortion.

Just like the bigger bass units, the E100HD does well in both closed and vented designs. With a properly tuned cabinet, the E100HD MKII delivers a firm and impressive bass.

All EAD units do exceptionally well with live acoustic music, like Jazz or blues and voices are very clear and present in the listening room.



E100HD MKII

Esoteric Audio Devices Sweden AB

Technical specifications

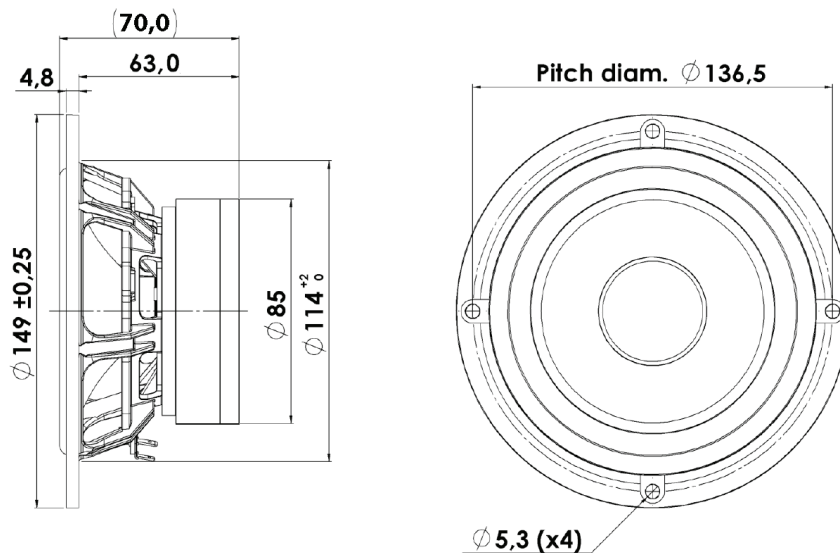

The new MKII chassis is more open than before, which improves the air flow.

Note, since we now use a new factory and measuring conditions, the measures are updated. We also recommend pairing drivers from the same factory. Please see our web site for replacement and upgrade policys. Measuring conditions: Factory new driver, "broken in" 30min. Half space free-field (2 pi) above 100 Hz. Anechoic room 6x7x8 meters. IEC specs. refer to IEC 60268-5 third edition. All EAD products are RoHS compliant. Sensitivity/2.83V/1m/ 300-1000Hz.

Note, data in this brochure is subject to change without notice.

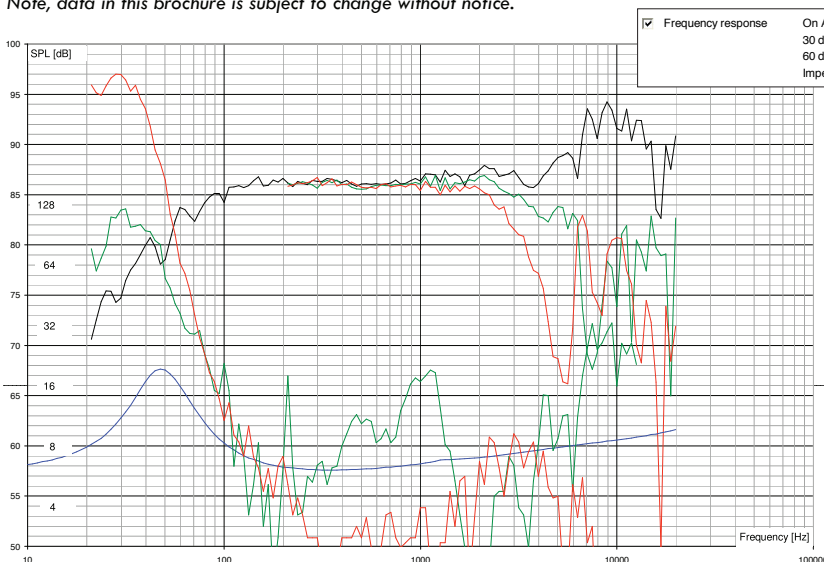

Technical specifications

Free air resonance Fs	Hz	46.0
Mechanical Q	Qm	1.63
Electrical Q	Qe	0.61
Total Q	Qt	0.44
Force factor	B1	3.8
Resistance DC	Re ohms	5.76
Dynamic mass	Md grams	5.3
Equiv air volume	Vas litre	19.6
Cone area	Sd sq. cms	79
SPL (0.3-1KHz), 2.83V	1m 1w	86.2
Min box volume (IB)	litres	3.0
Ch	uF	363.5
Le	mH	0.1
Lh	mH	32.9
Rh	Ohm	15.5
Power handling 100h	watts RMS	TBA
Power handling Long term	watts RMS	75
Xmax lin (WW-TP)/2	m.m.	+/- 3.6
Xmax lin (WW-TP)/2+(25%×TP)	m.m.	+/- 4.8
X mech	m.m.	+/- 9.9
Freq. range, free air	Hz	46-25K

